

PL - Zachowaj w razie reklamacji !!! / BG - Пазете в случай на рекламация !!! / CZ - Uchovávejte pro případ stížnosti !!! / DE - Bewahren Sie das Etikett für Reklamationen !!! / ENG - Keep the label for complaints !!! / ES - Conservar en caso de reclamación !!! / EST - Kaebuse korral hoidke alles !!! / FR - Conserver en cas de réclamation !!! / HR - Zadržite u slučaju prigovora !!! / HU - Tartsa fenn panasz esetén !!! / IT - Conservare in caso di reclamo !!! / LT - Laikykite skundo atveju !!! / LV - Saglabājiet sūdzības gadījumā !!! / NL - Bewaren in geval van een klacht !!! / PO - Guardar em caso de reclamação !!! / RO - Păstrați în cazul unei reclamații !!! / RU - Сохранить в случае рекламации !!! / S - Förvara vid klagomål !!! / SK - Majte v prípade reklamácie !!! / SLO - Hranite v primeru pritožbe !!! / SRB - Задржите у случају жалбе !!! / TR - Şikayet durumunda saklayın !!! / UKR - Зберігати у разі скарги !!!

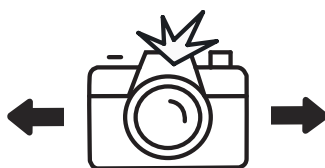

Nazwa wyrobu: Product Name: XXXXXXXXXX			
Kolor: XXXXXXXXXX Color: XXXXXXXXXX			
Data produkcji: Production date:	Pakujący: Packager:	Szkló: Glass:	Kod paczki: Code packages:
0000-00-00	xx0/xx0	0	0xxxxx00-000-0/0

DALLAS 1501

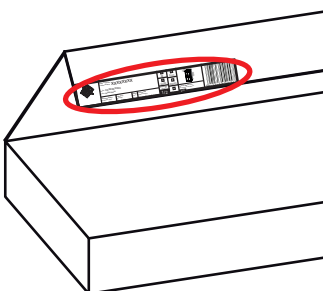
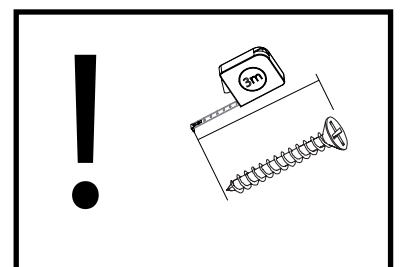
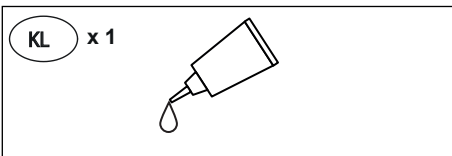
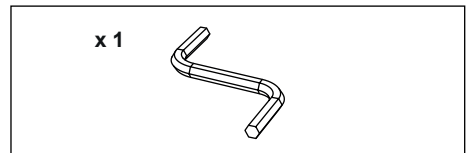
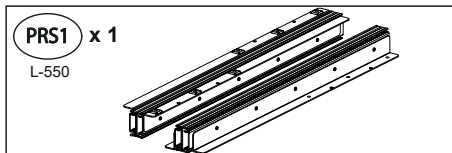
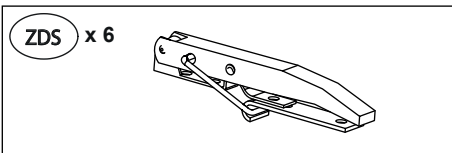
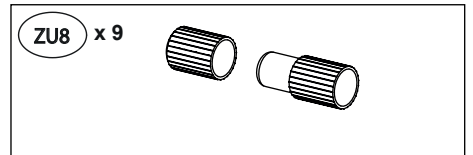
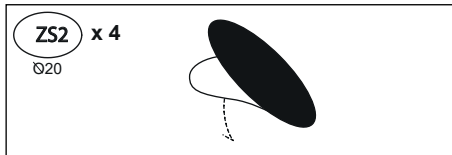
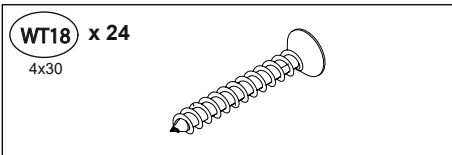
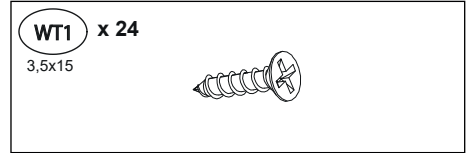
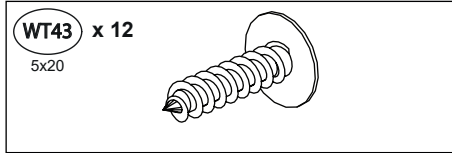
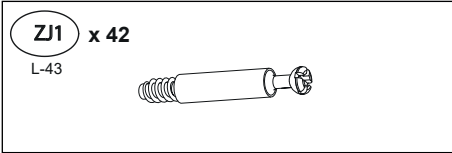
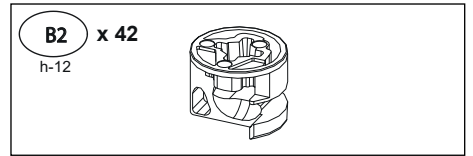
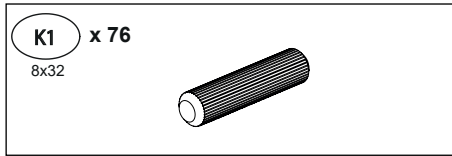
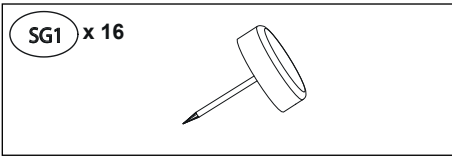

DALLAS 1501

	CODE				
1	Dallas1501_10	888	400	2	2/2
2	Dallas1501_01	888	505	1	1/2
3	Dallas15_11	826	100	2	2/2
4	Dallas15_12	455	100	2	2/2
5	Dallas15_13	455	100	2	2/2
6	Dallas15_04	730	124	2	1/2
7	Dallas15_02	730	124	2	1/2
8	Dallas15_05	730	108	2	1/2
9	Dallas15_03	730	108	2	1/2
10	Dallas15_07	630	90	4	1/2

	CODE				
11	Dallas15_08	630	108	2	1/2
12	Dallas15_06	630	108	2	1/2
13	Dallas15_09	794	124	2	1/2
14	Dallas15_14	400	100	2	2/2
15	Dallas1501_15	888	505	1	1/2

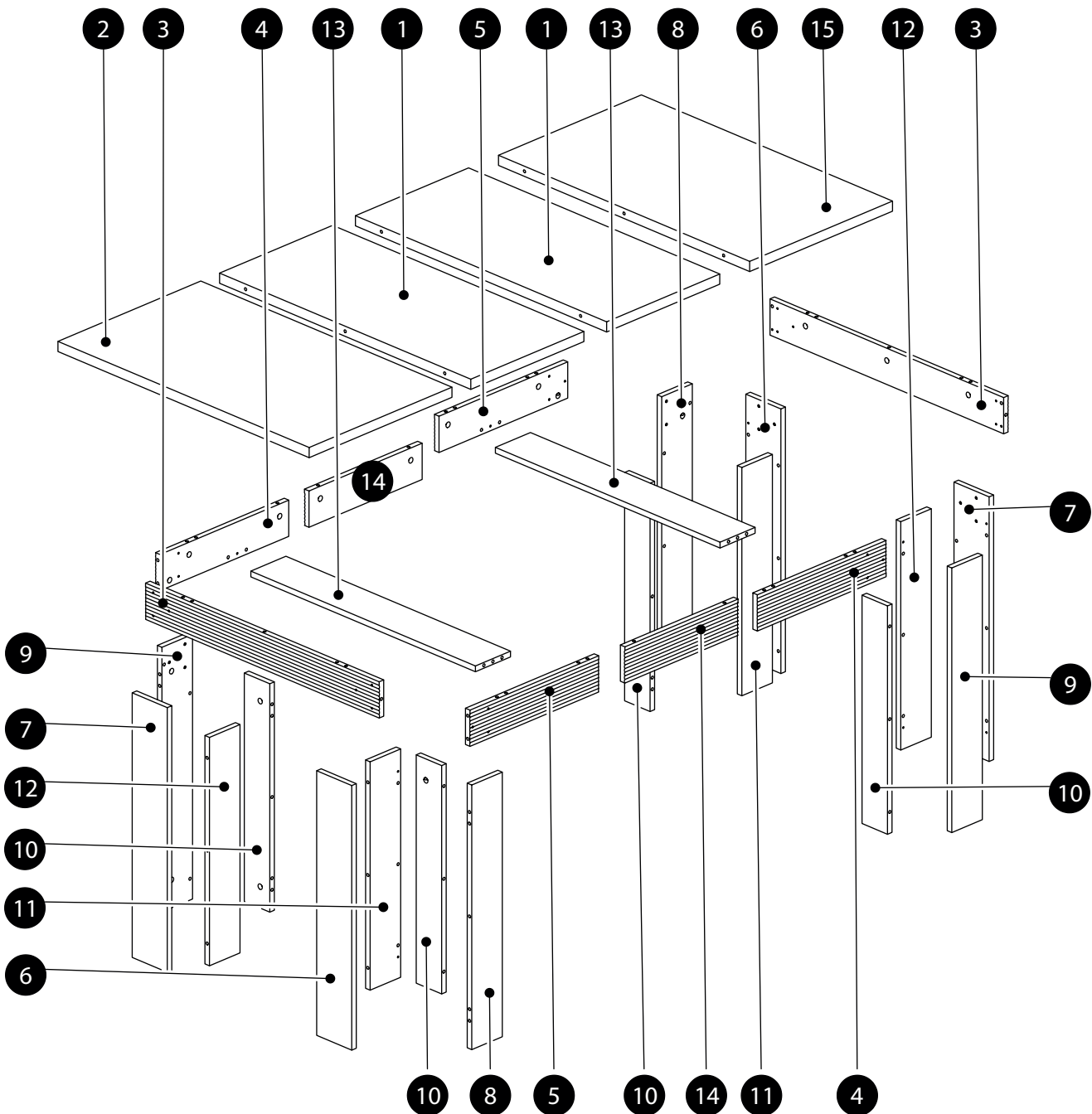

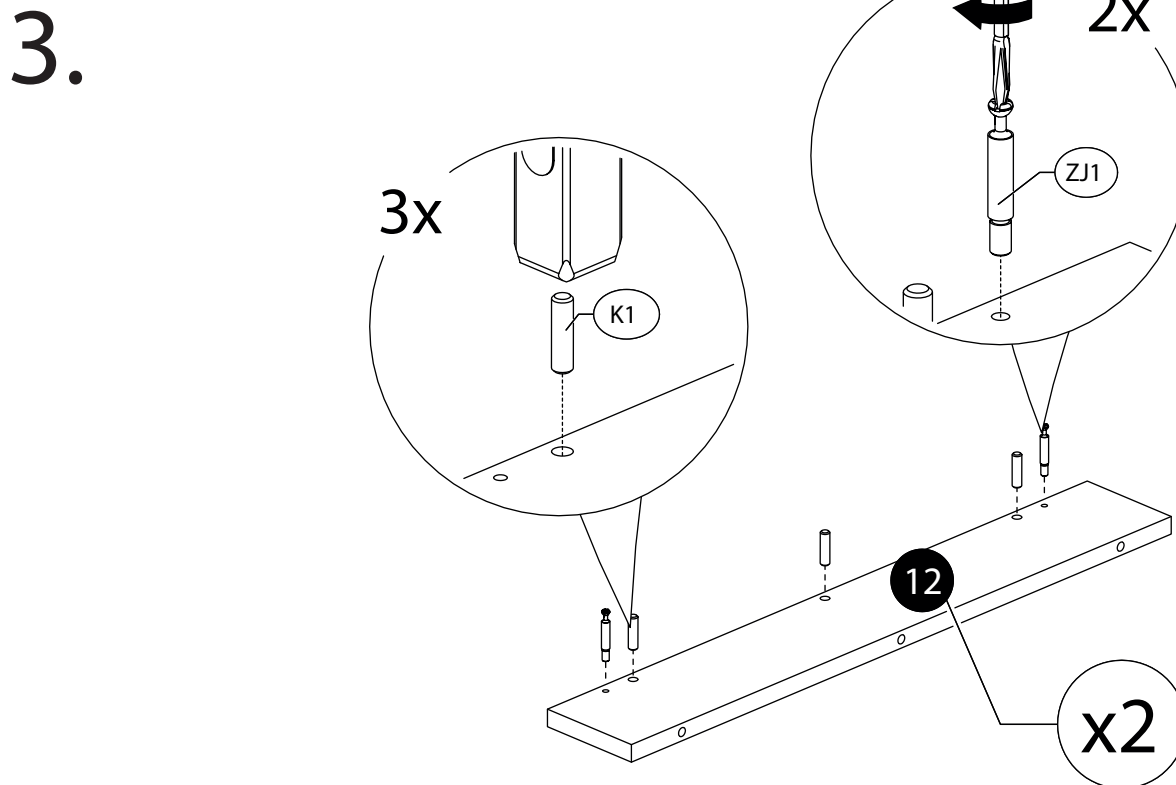
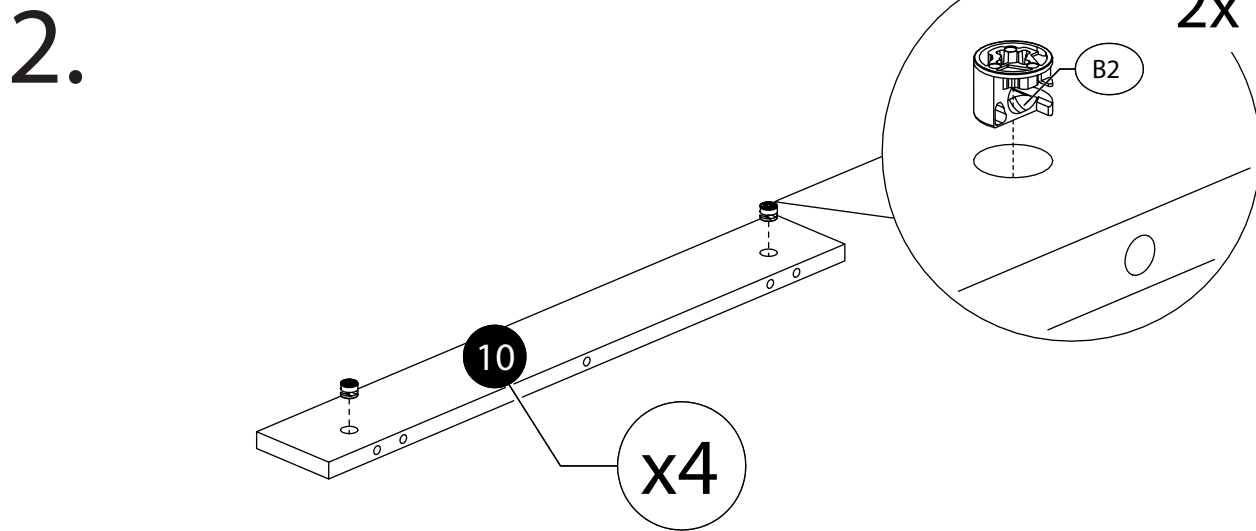
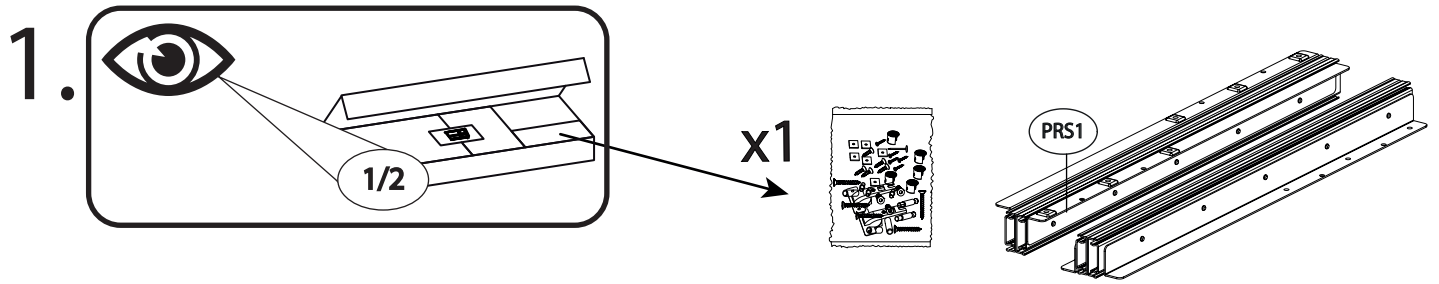

4.

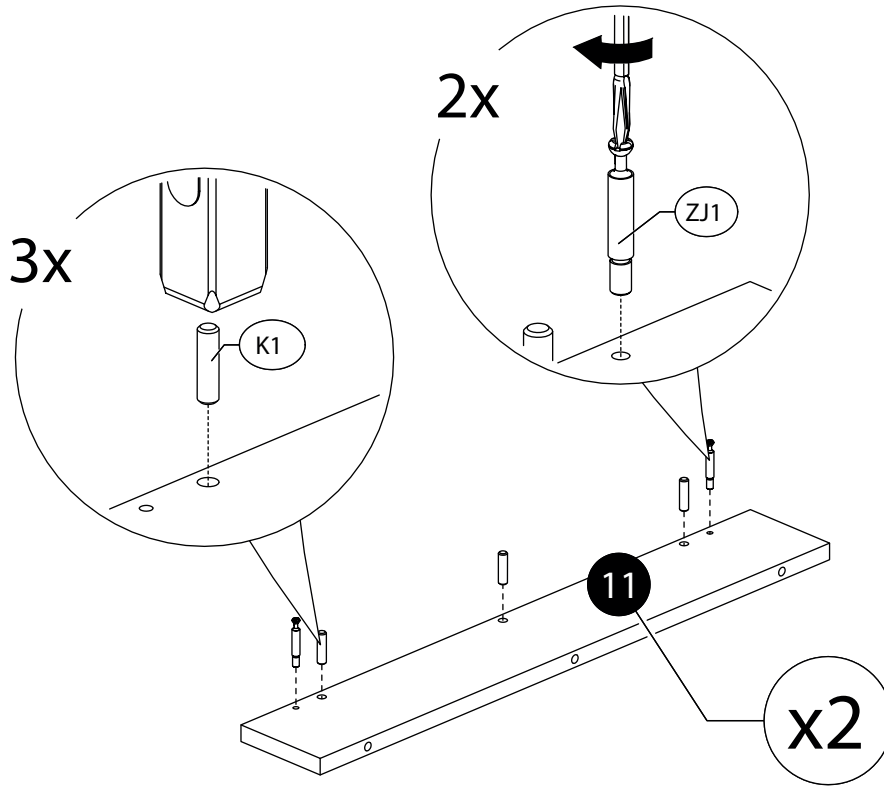

5.

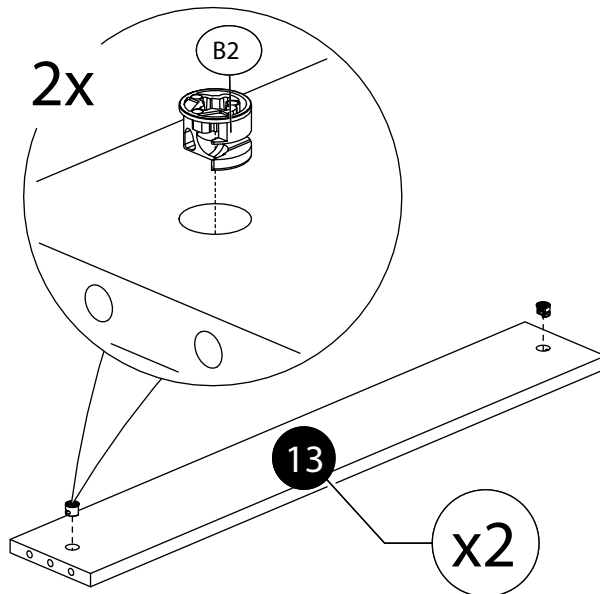

6.

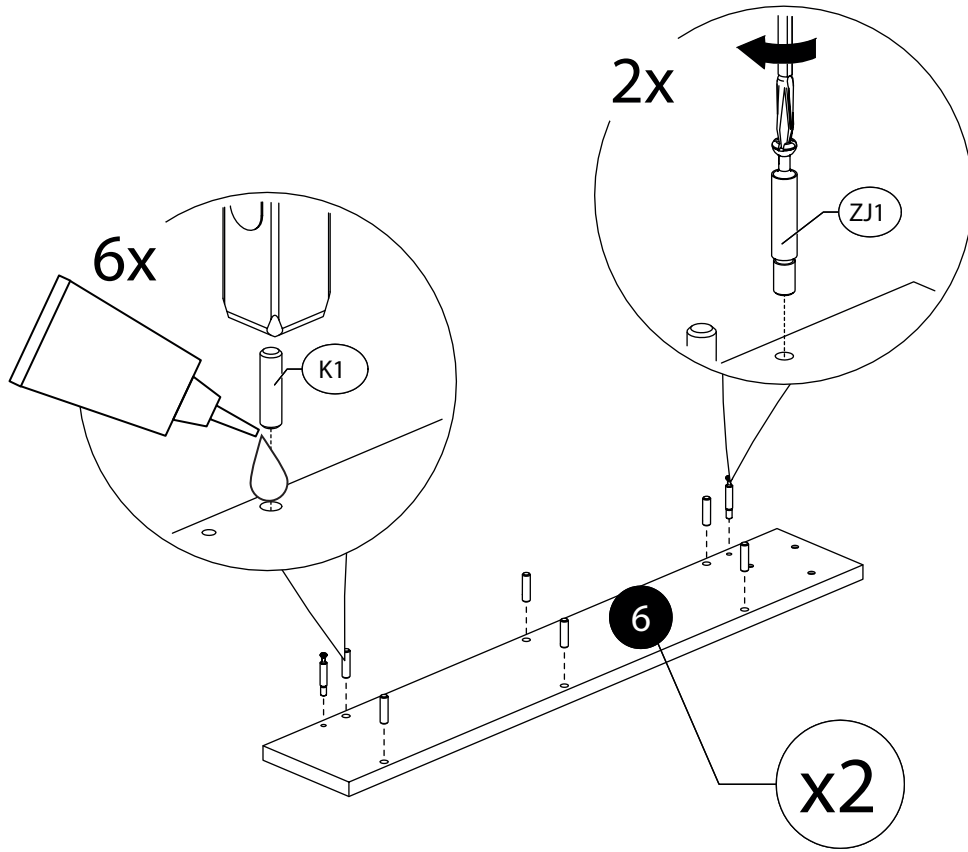

7.

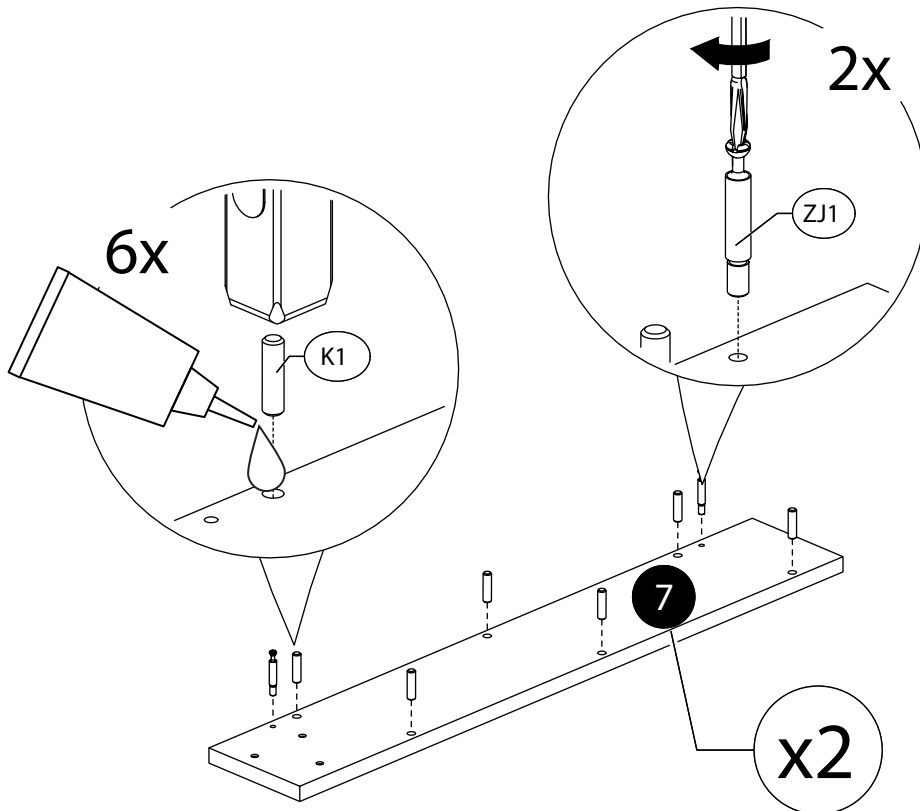

8.

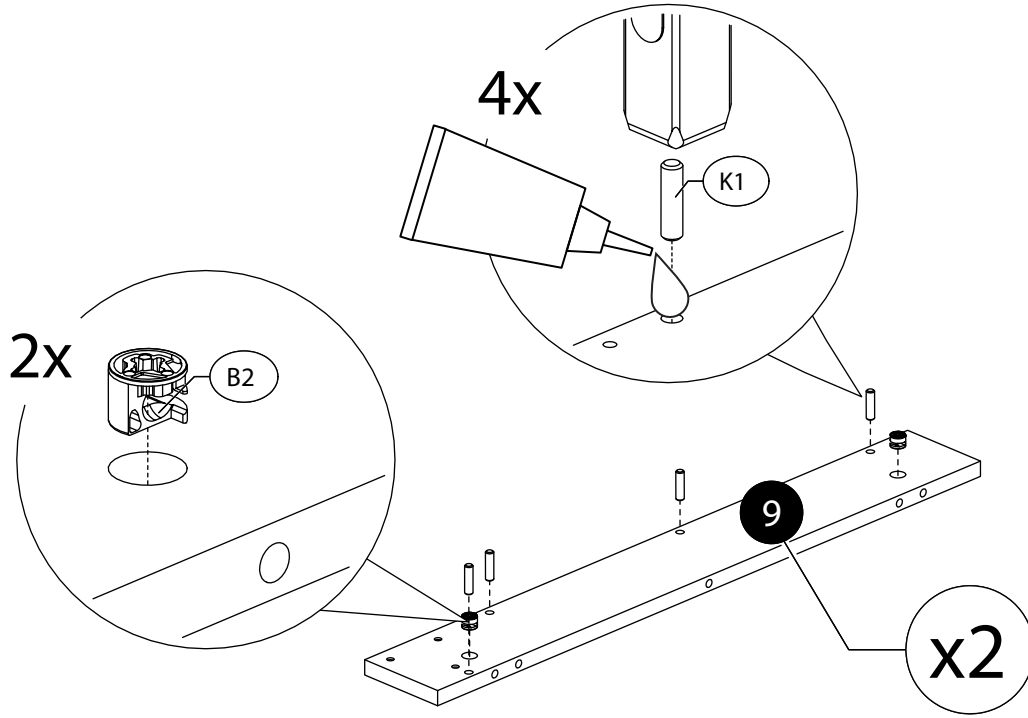

9.

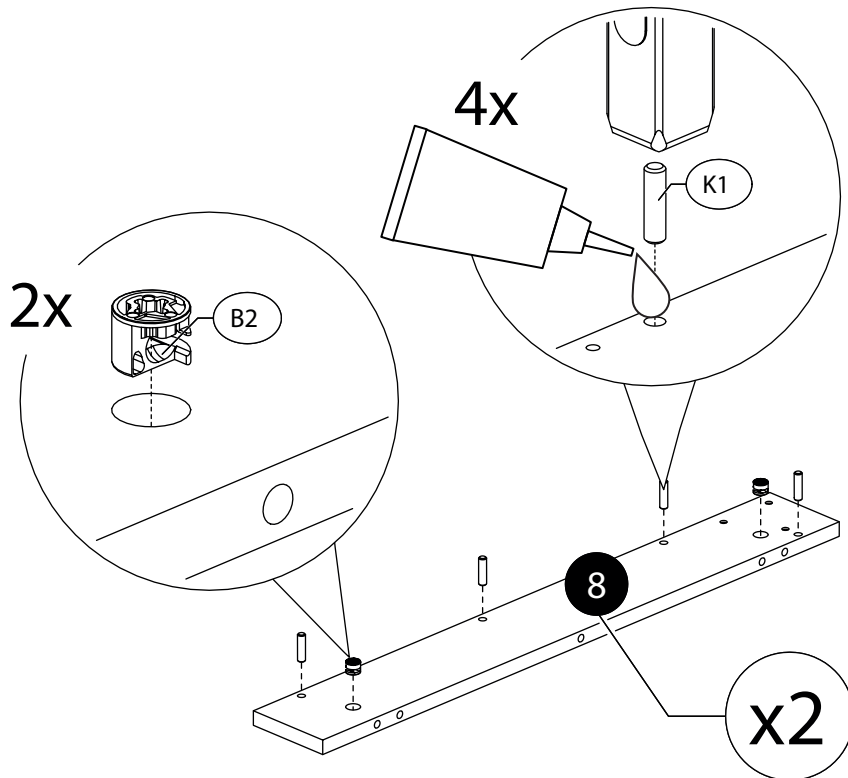

10.

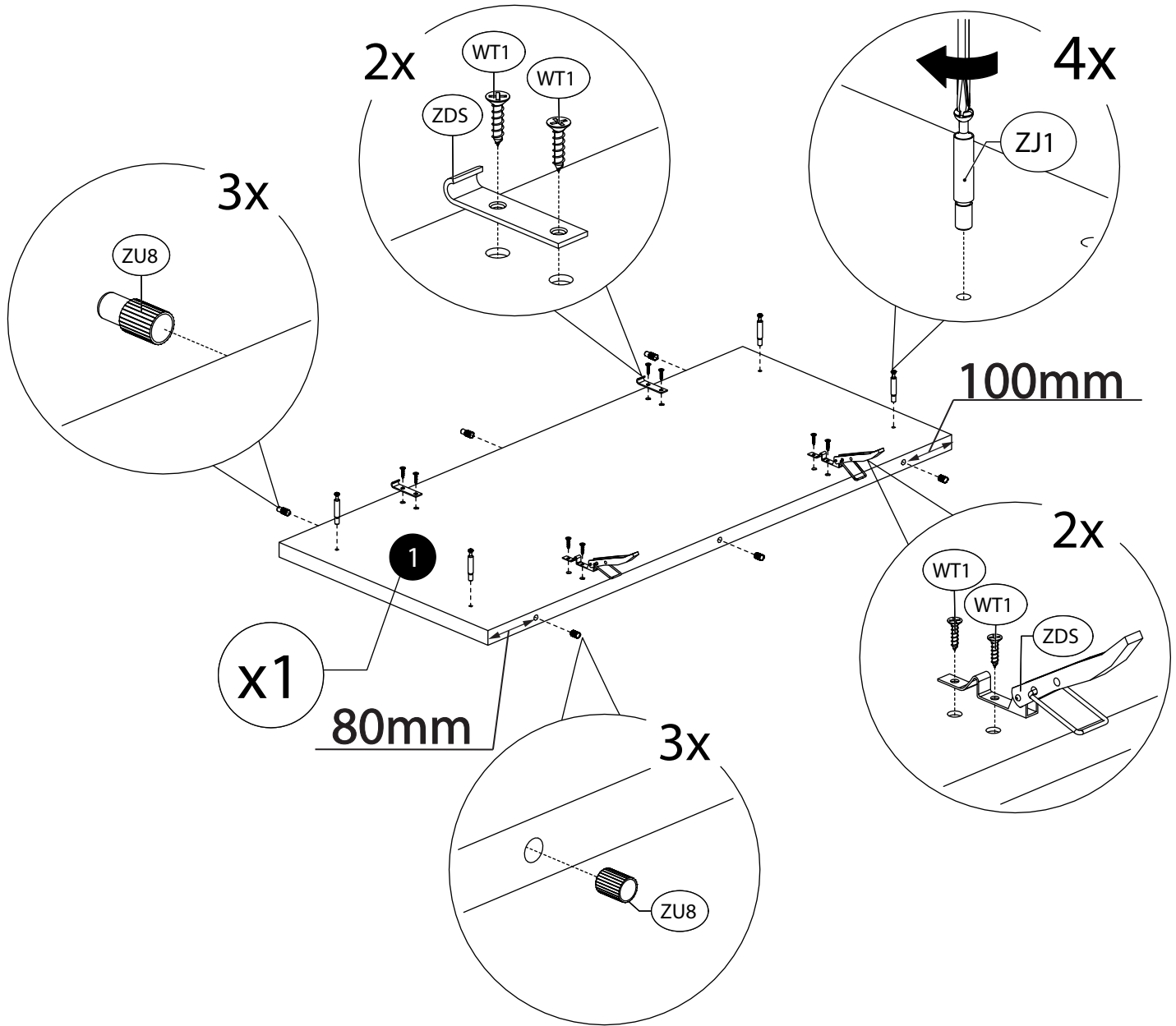

11.

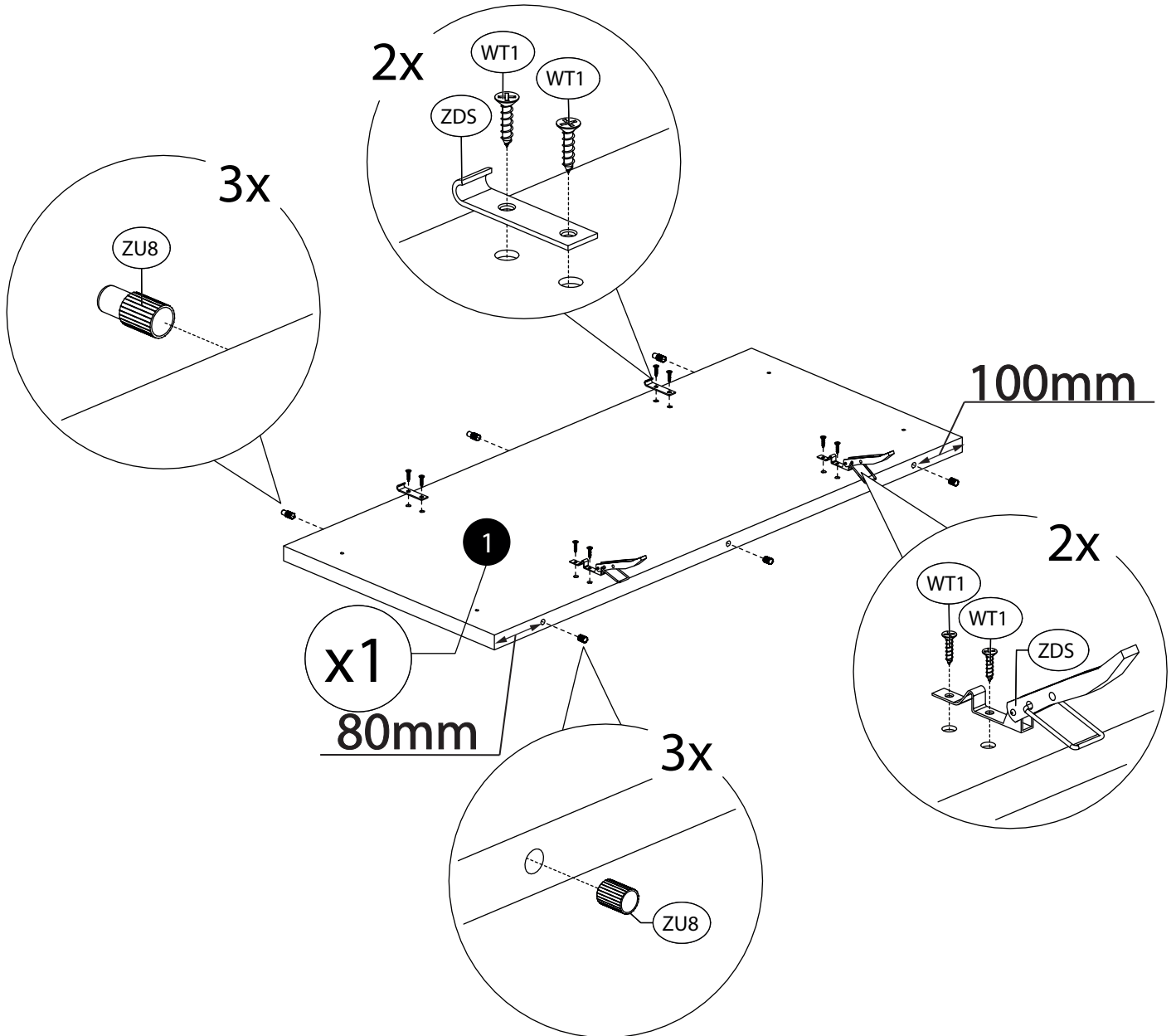

12.

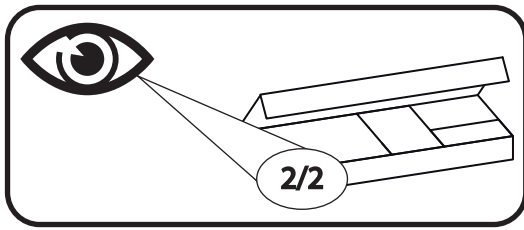

13.

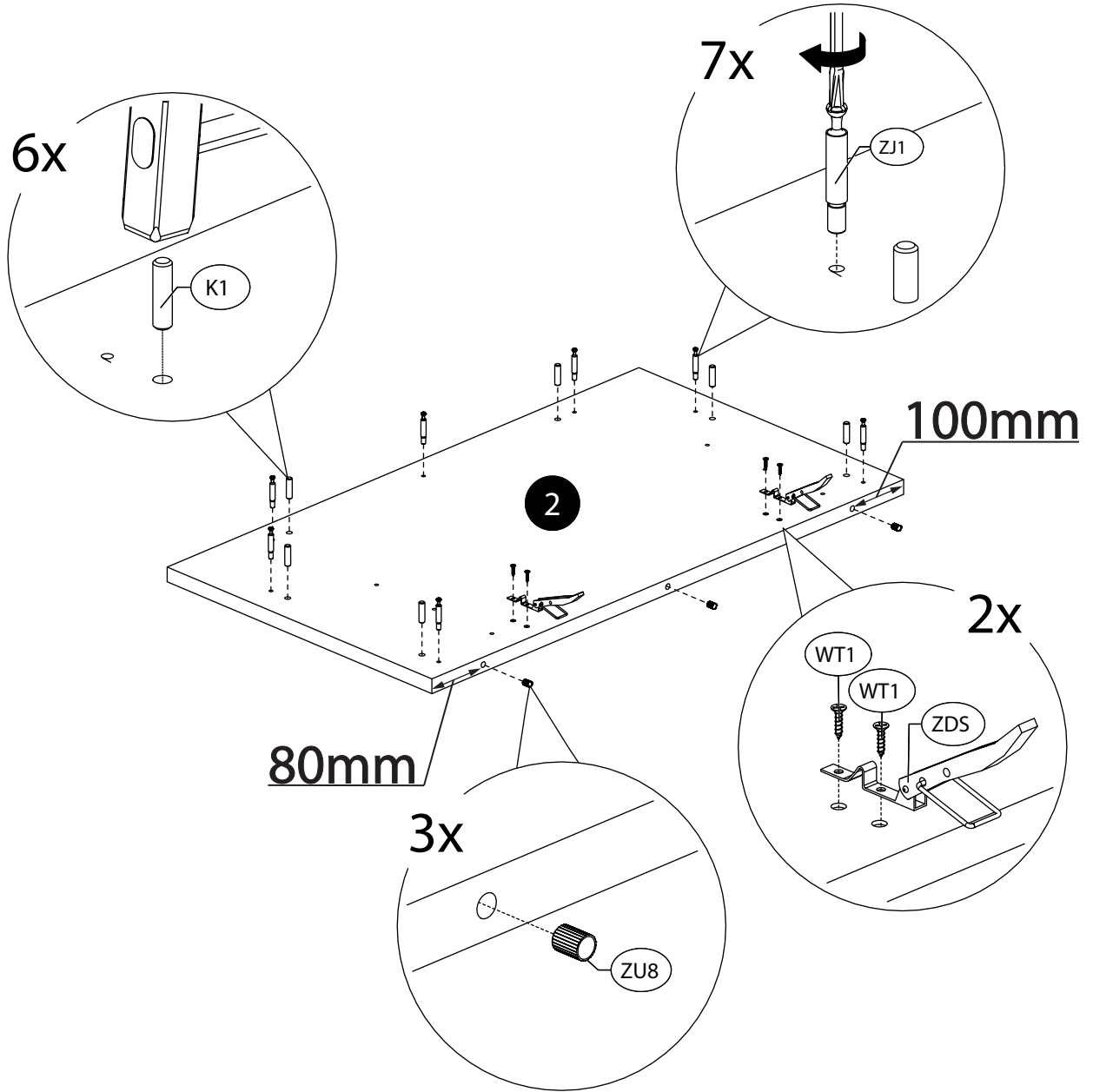

14.

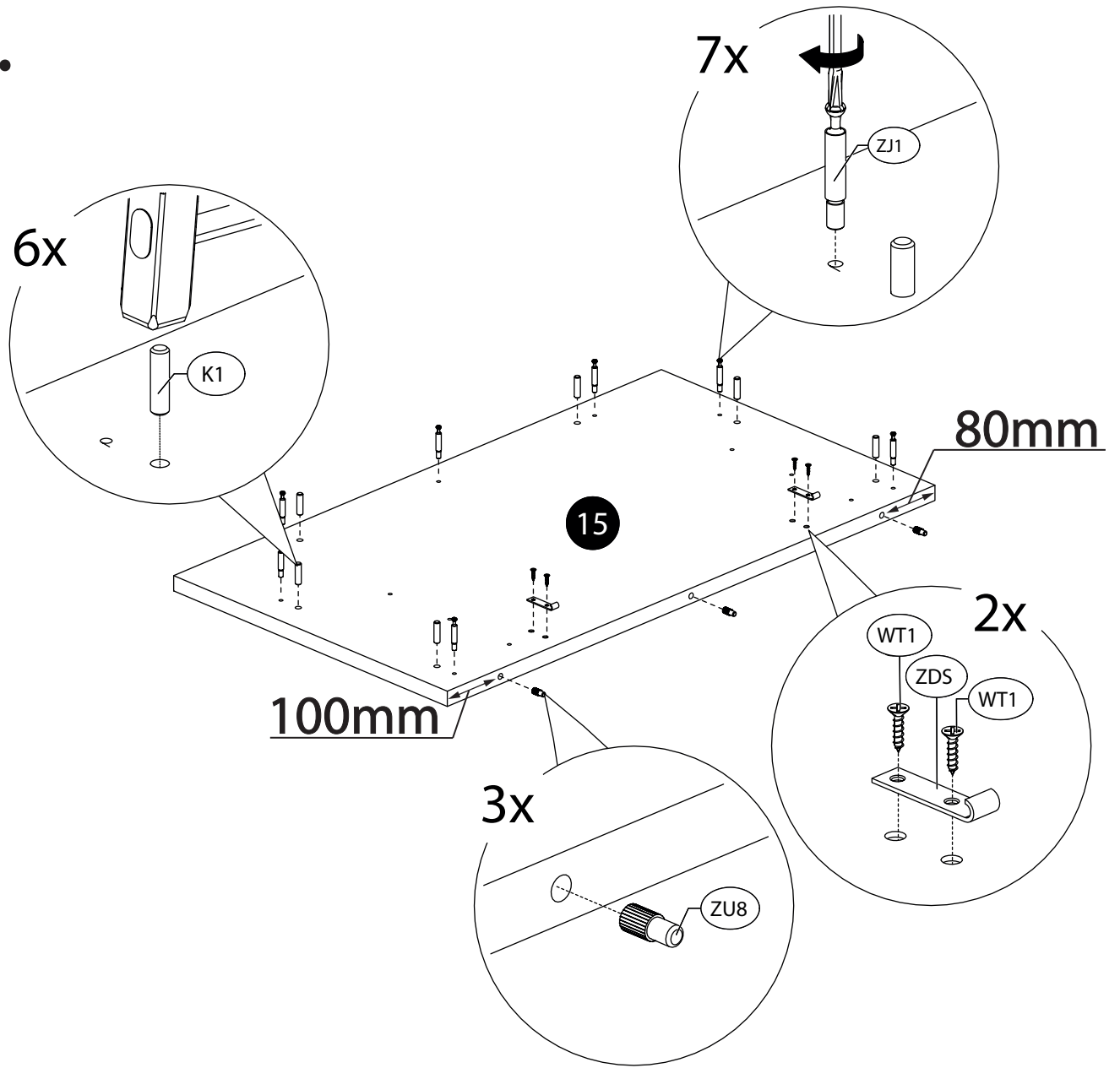

15.

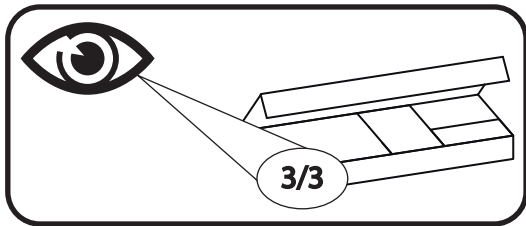

16.

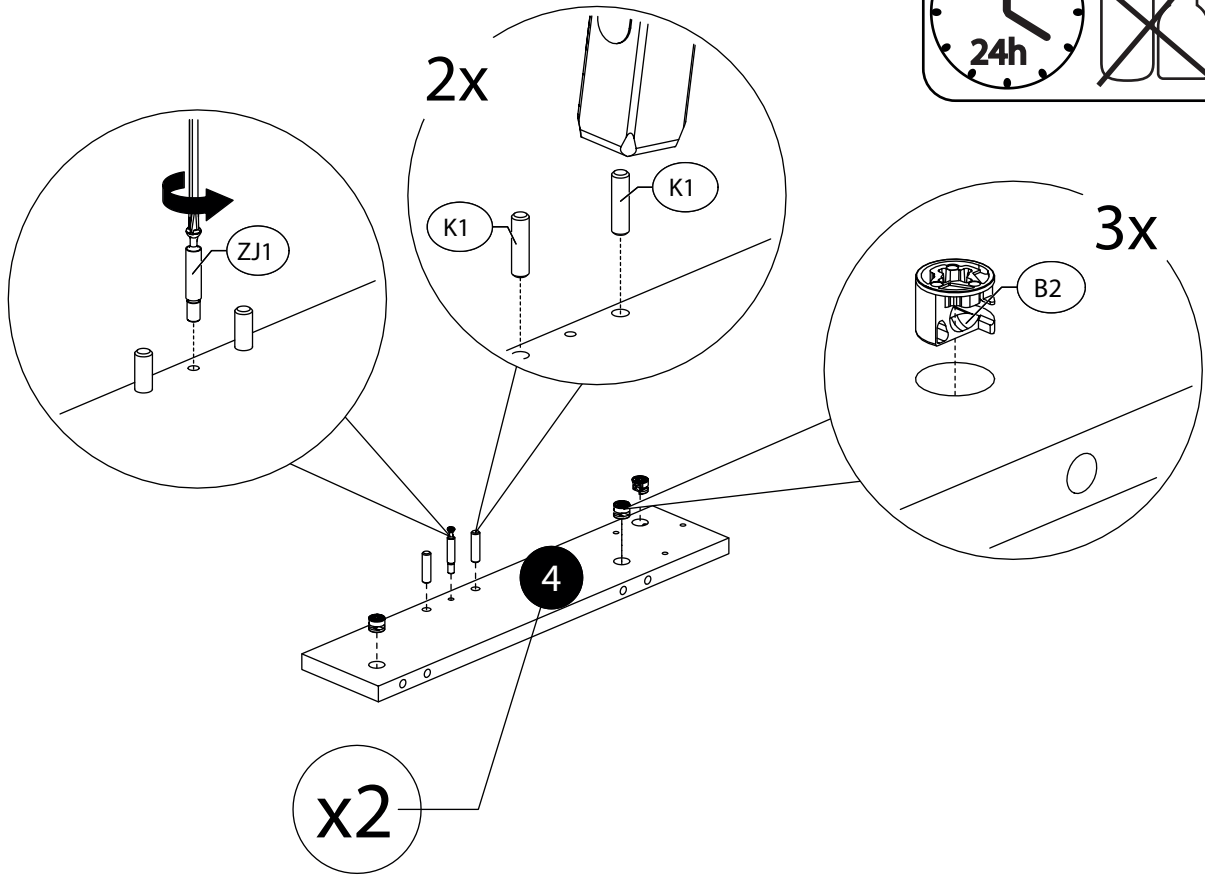

17.

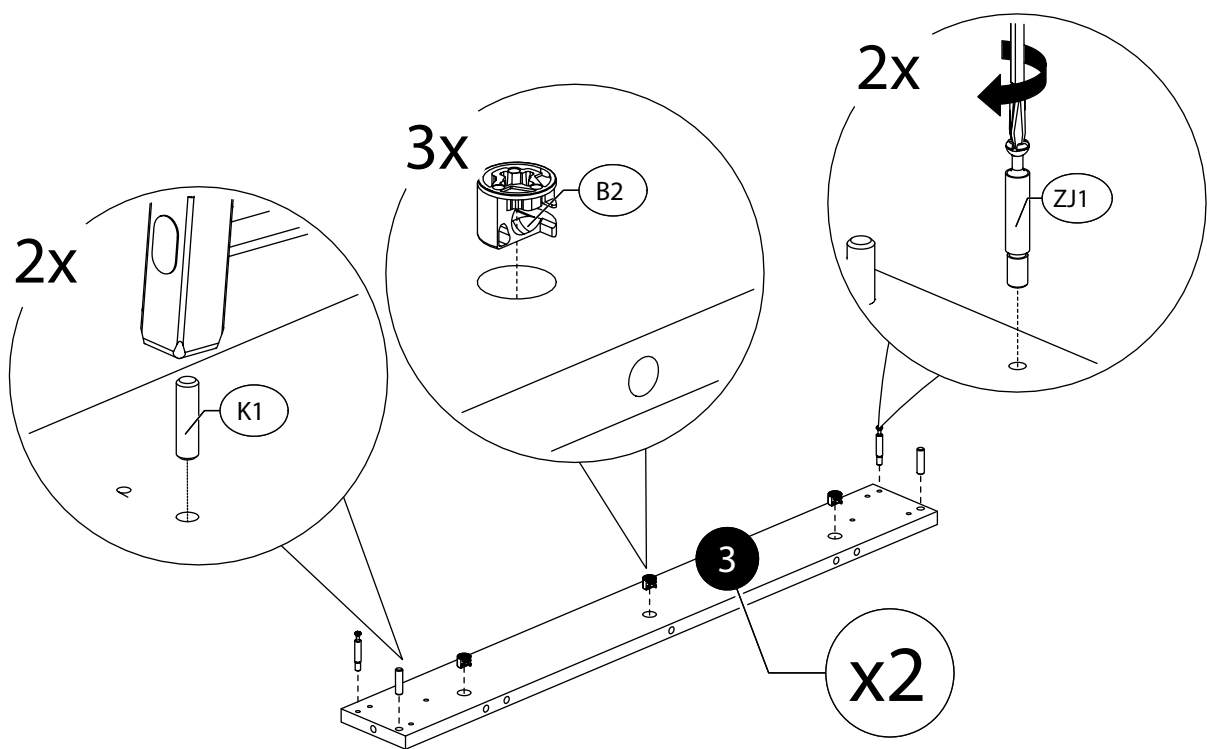

18.

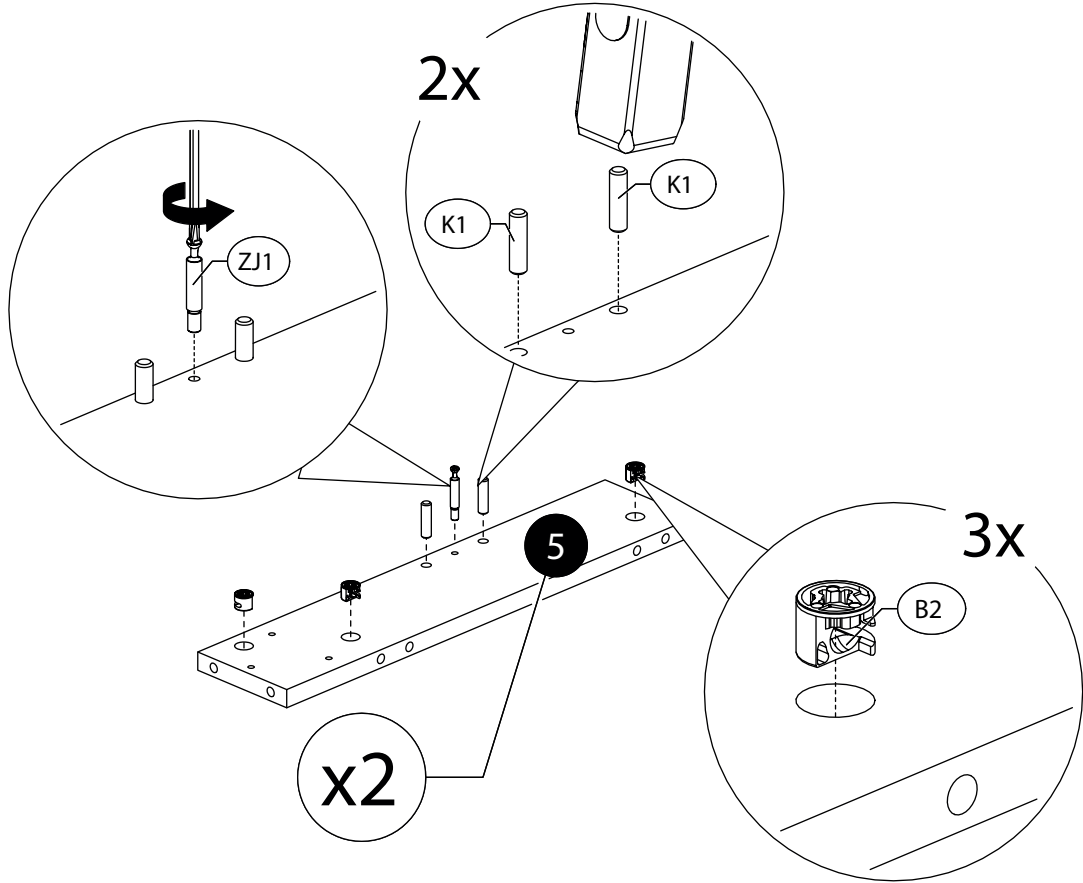

19.

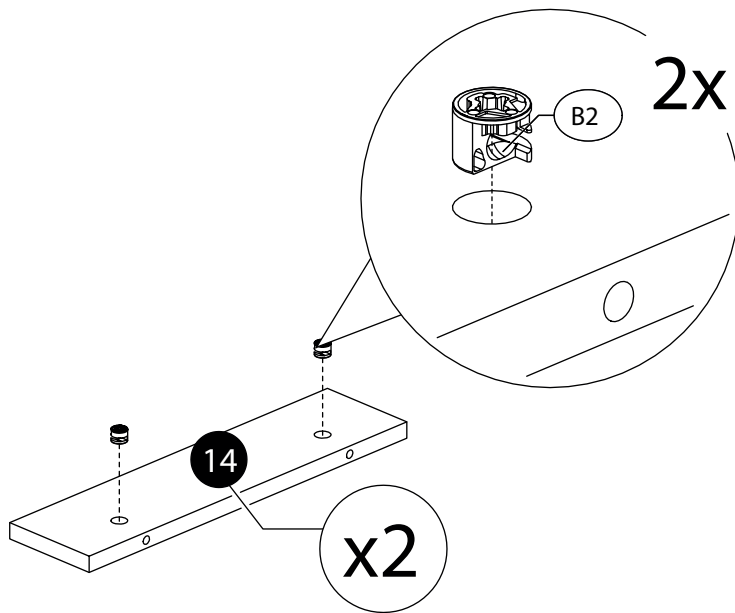

20.

x1

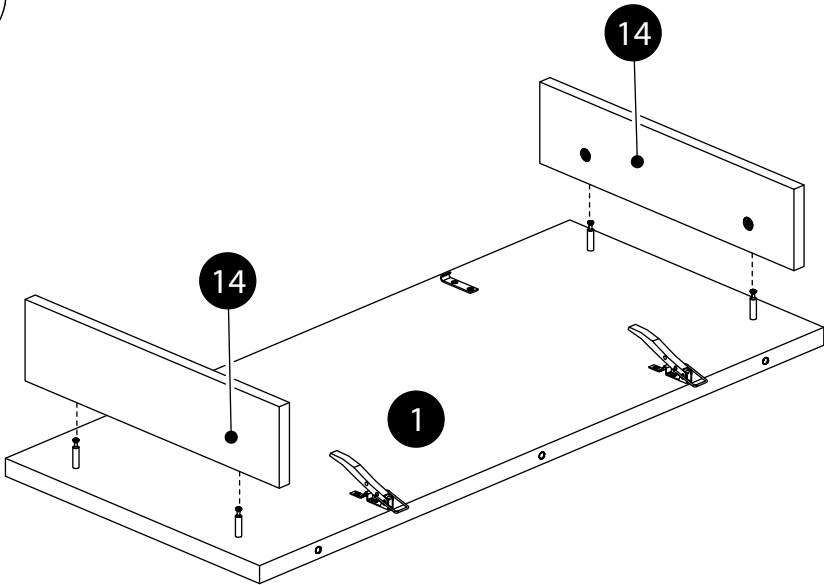

21.

x2

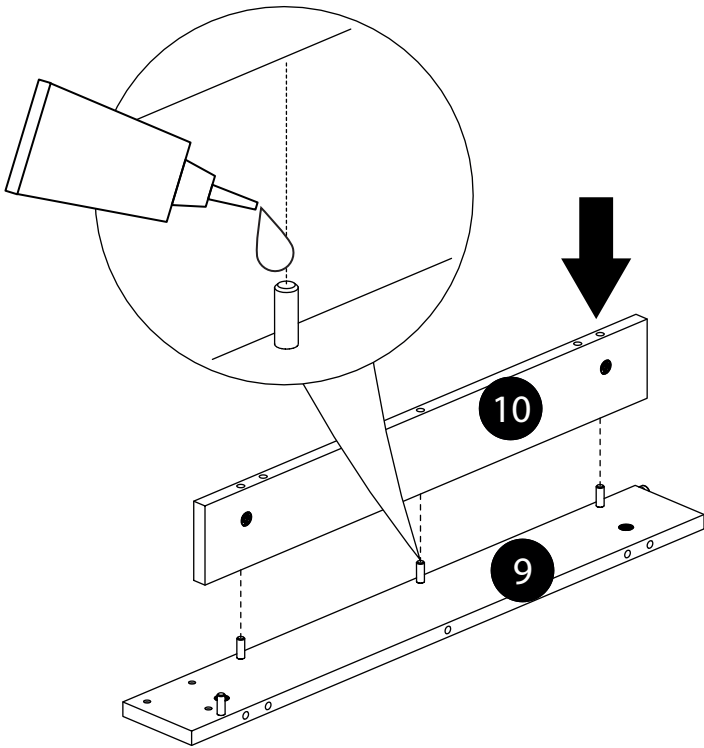

22.

x2

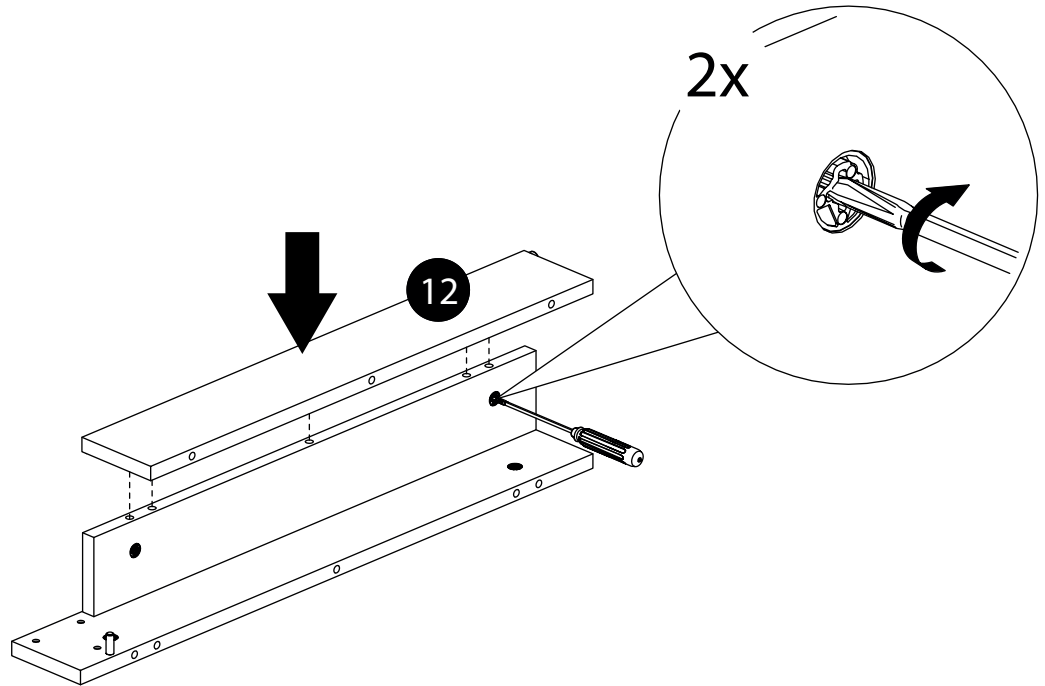

23.

x2

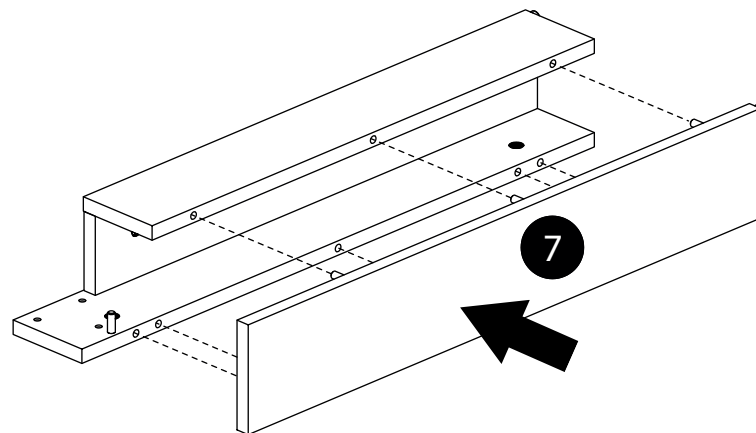

24. (x2)

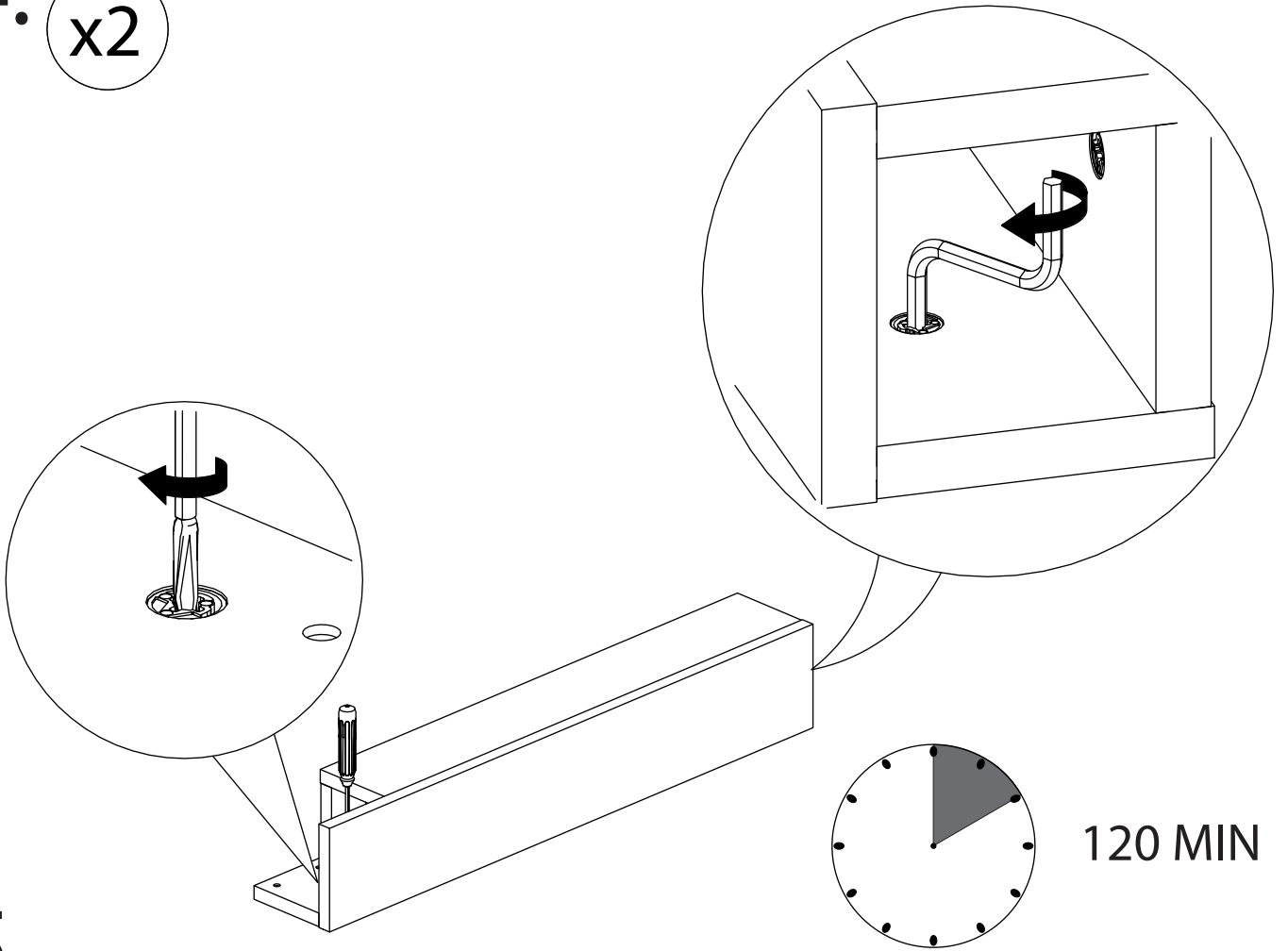

25.

(x2)

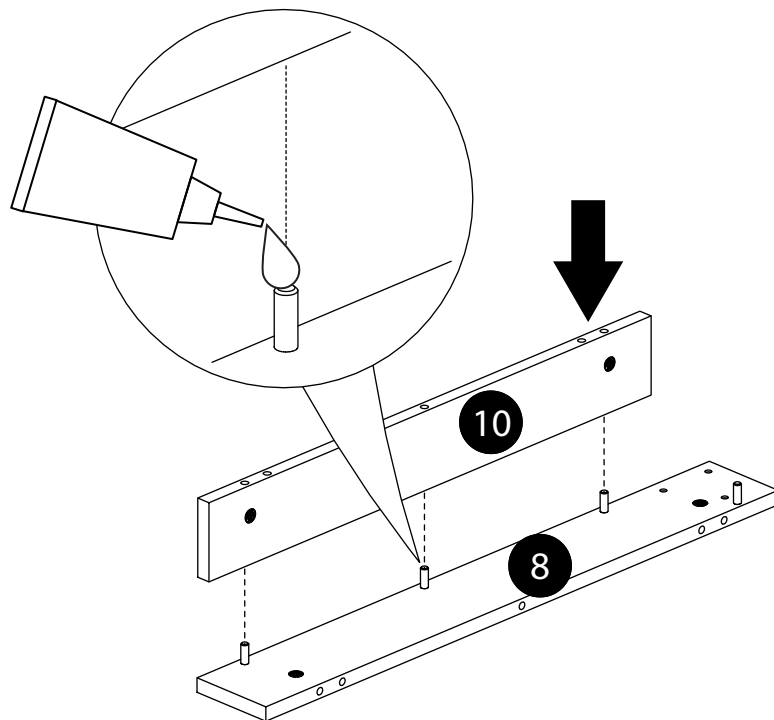

26.

x2

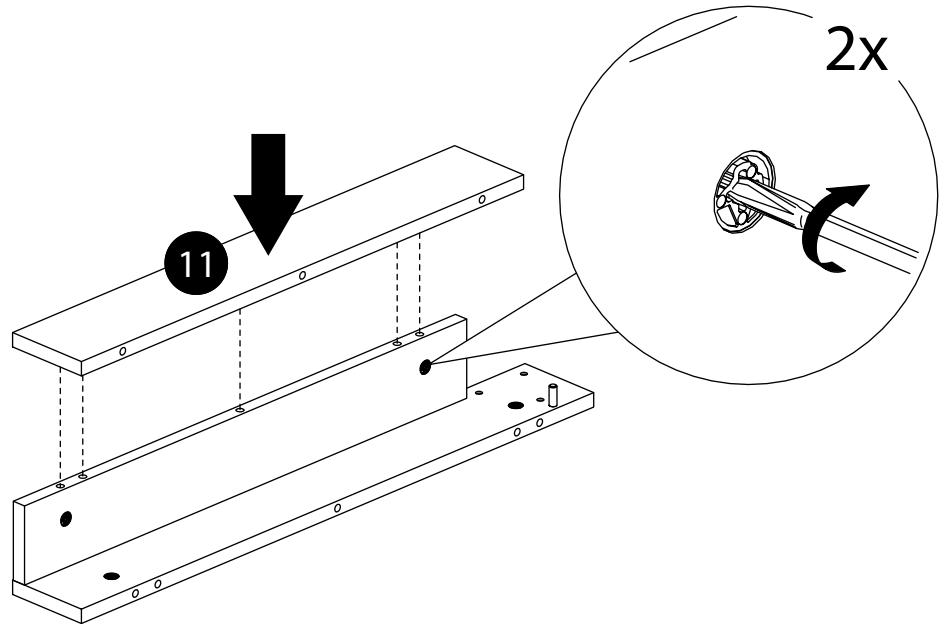

27.

x2

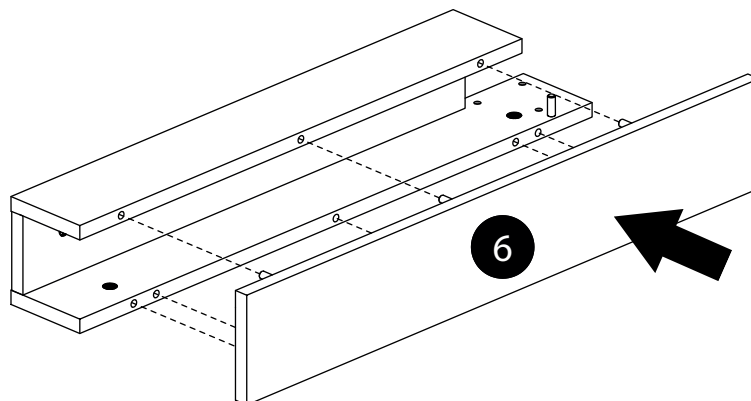

28.

x2

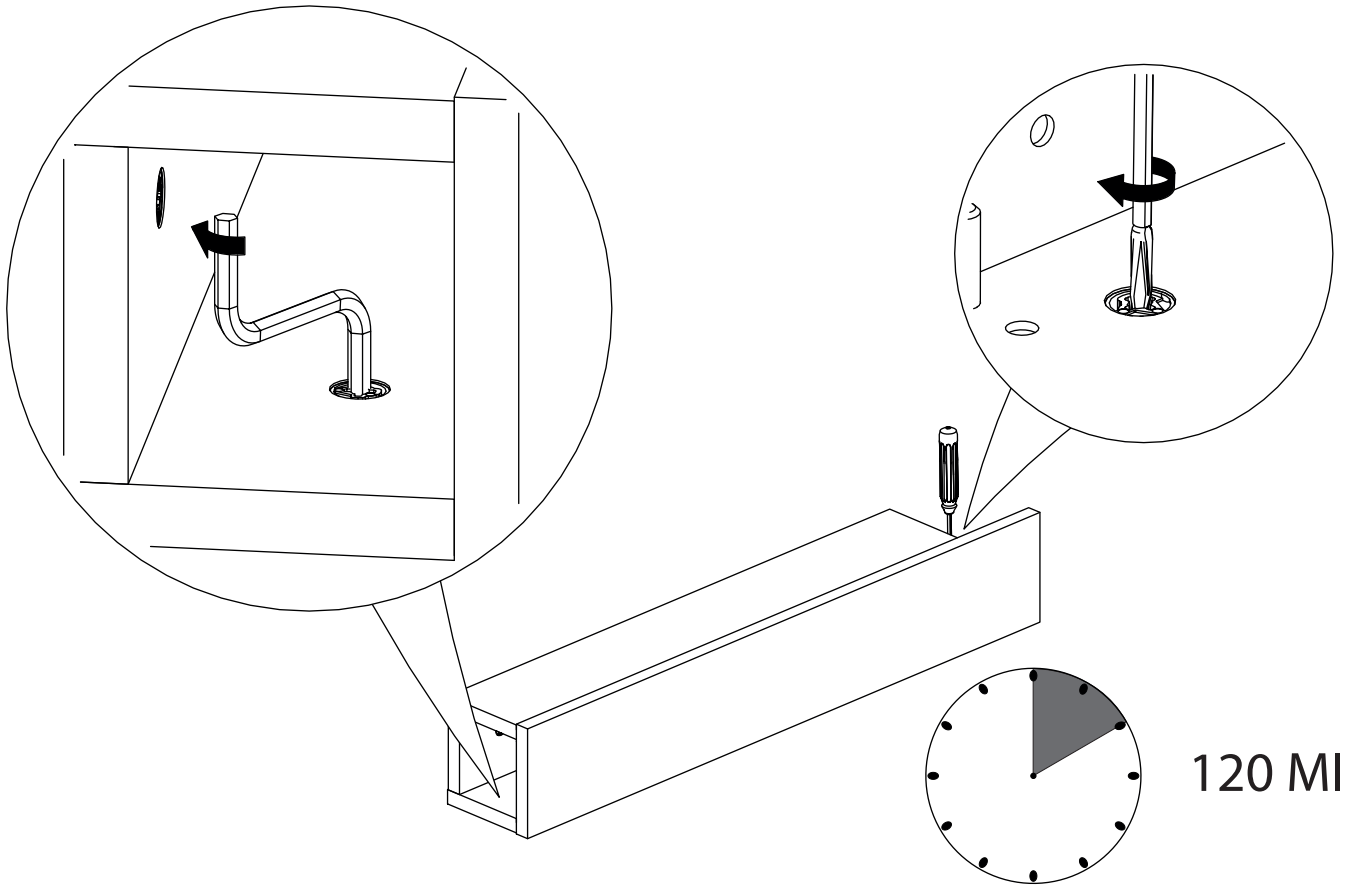

120 MIN

29.

x2

4x

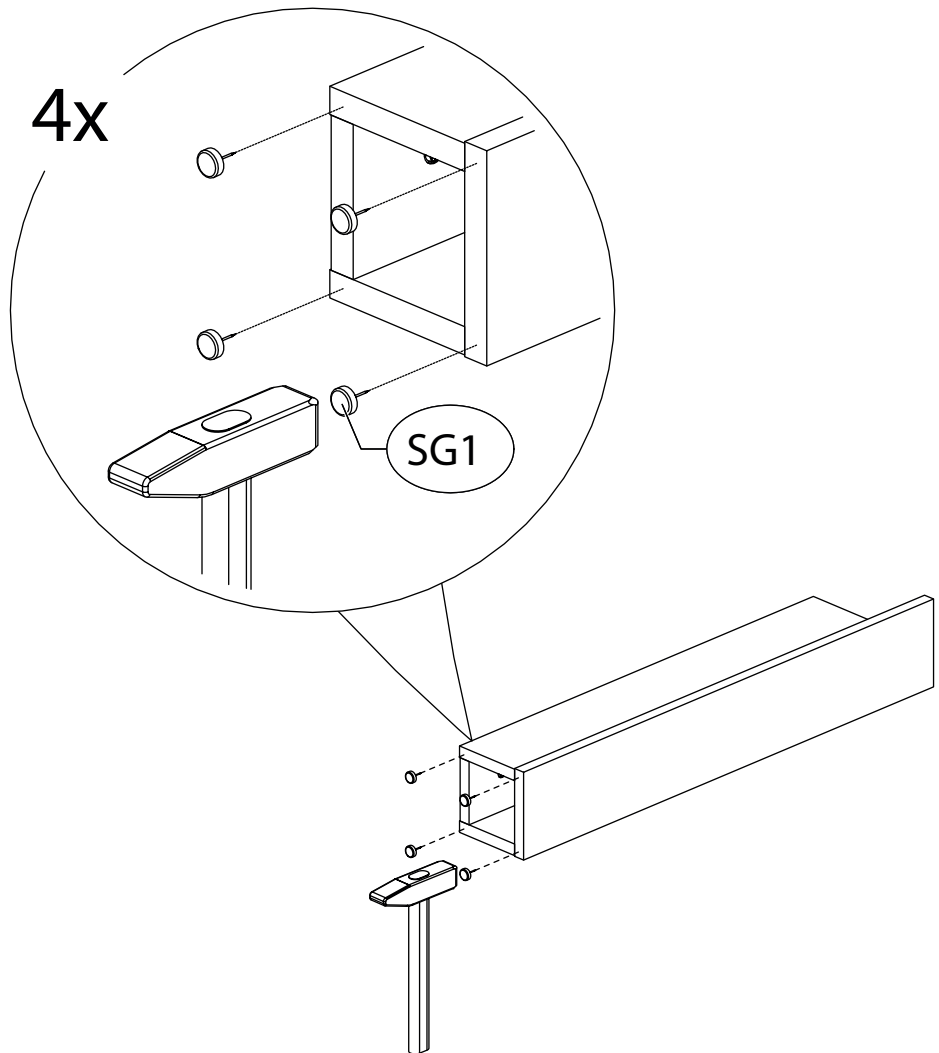

SG1

30.

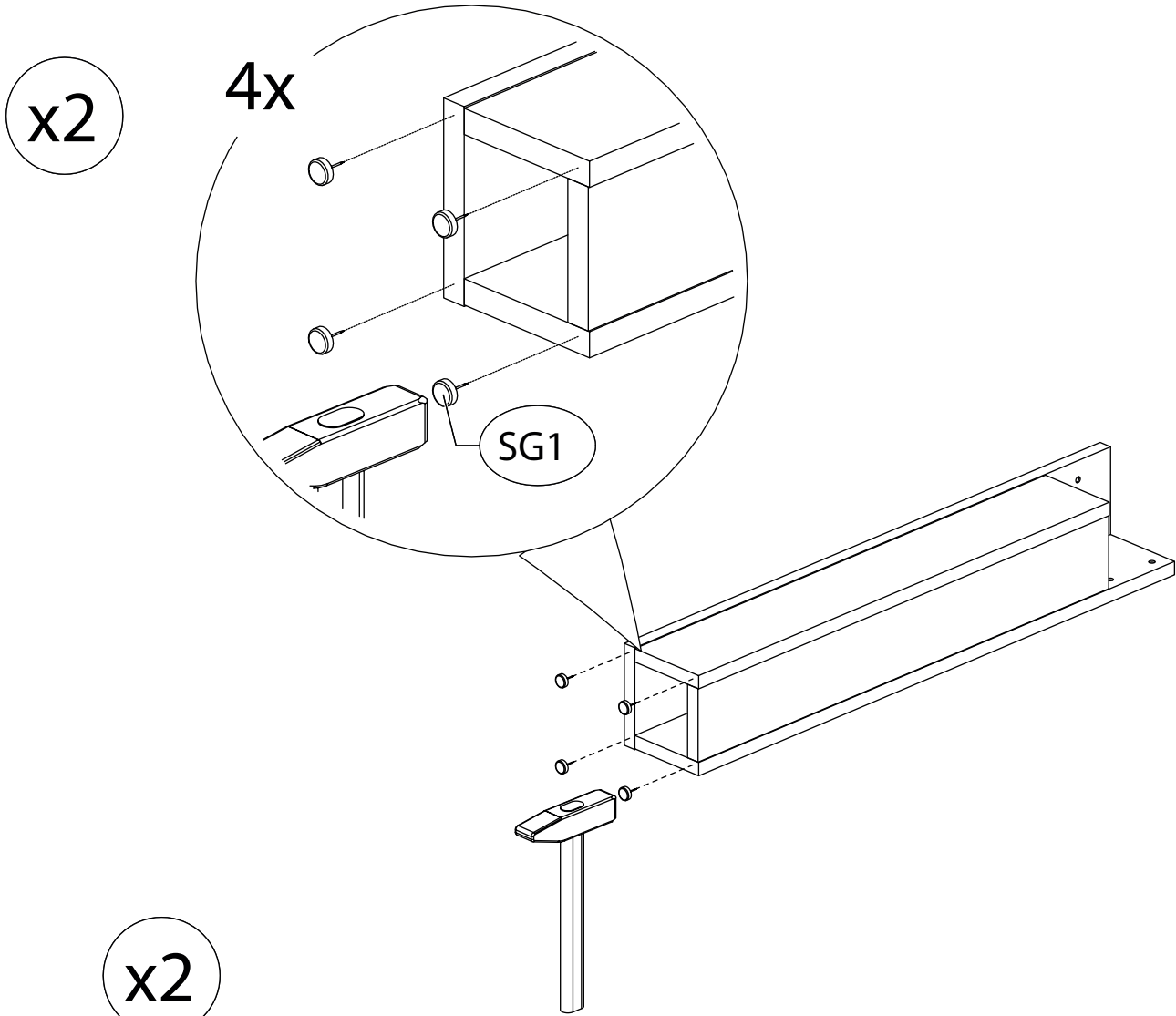

31.

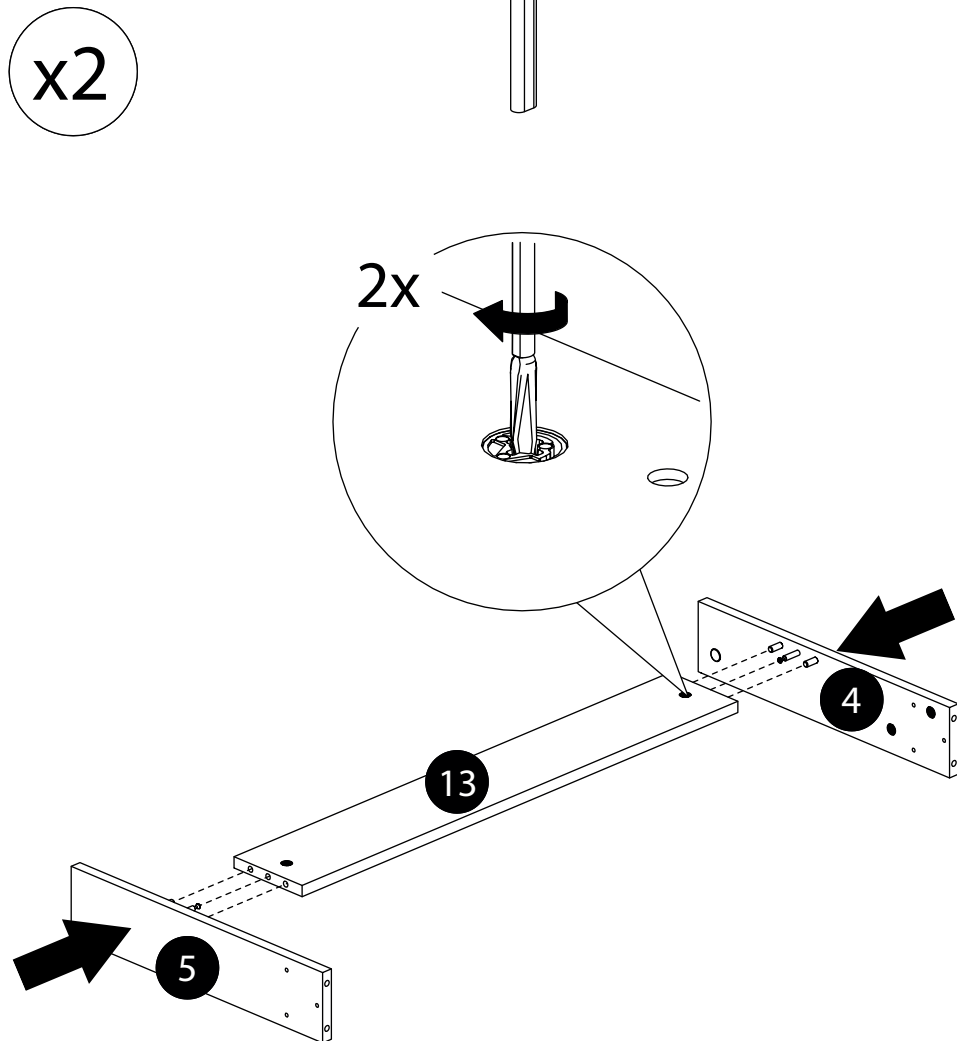

32.

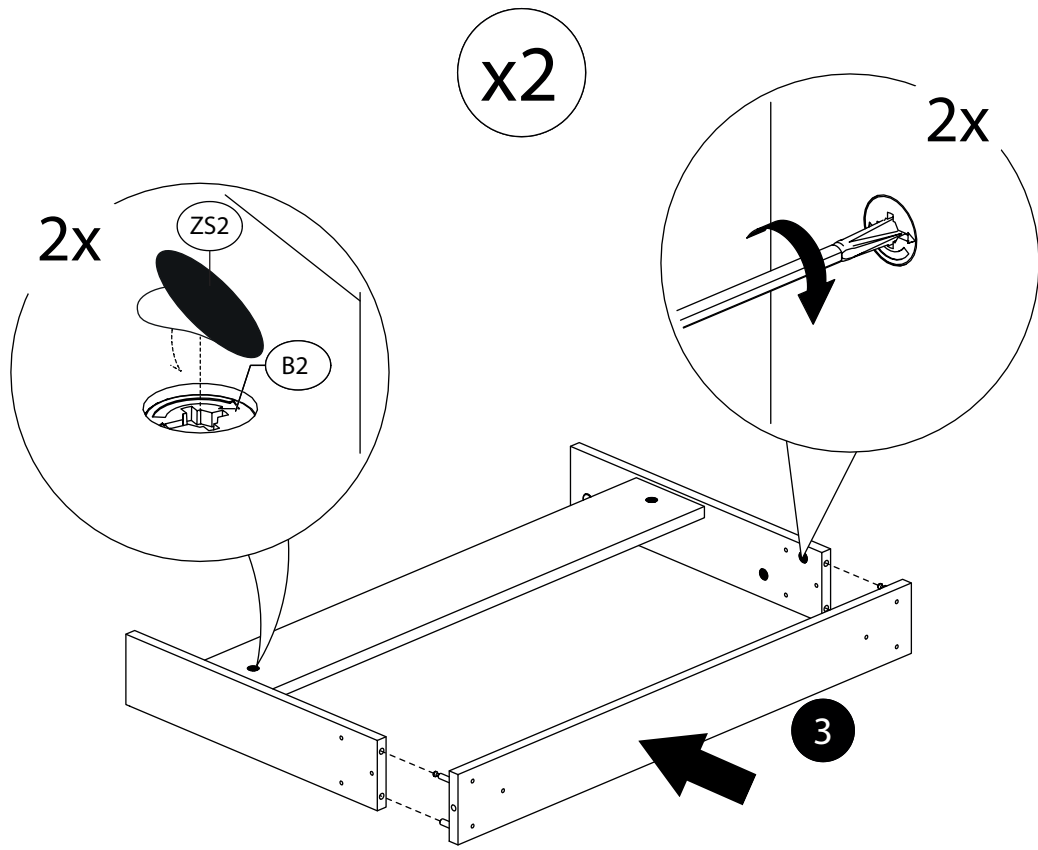

33.

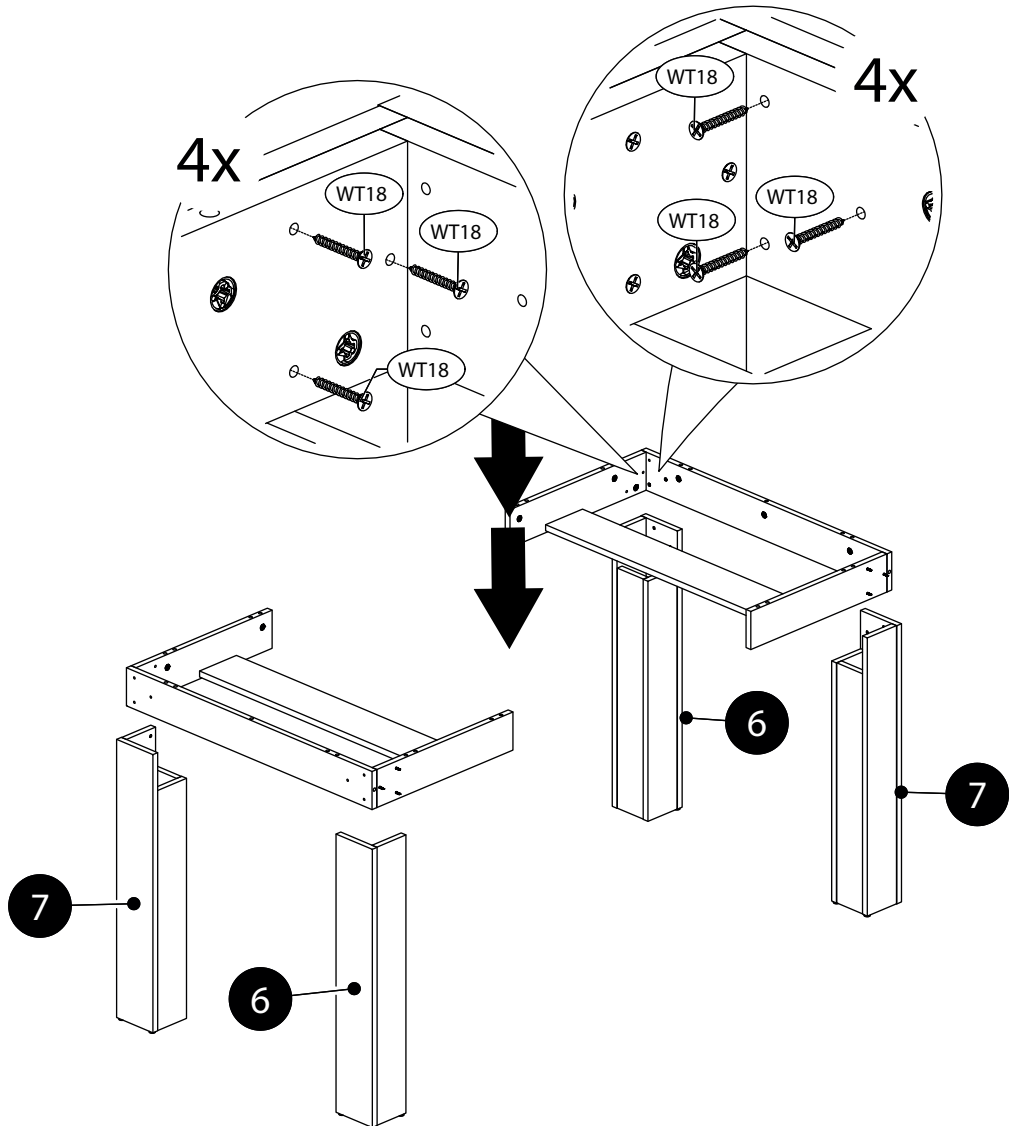

34.

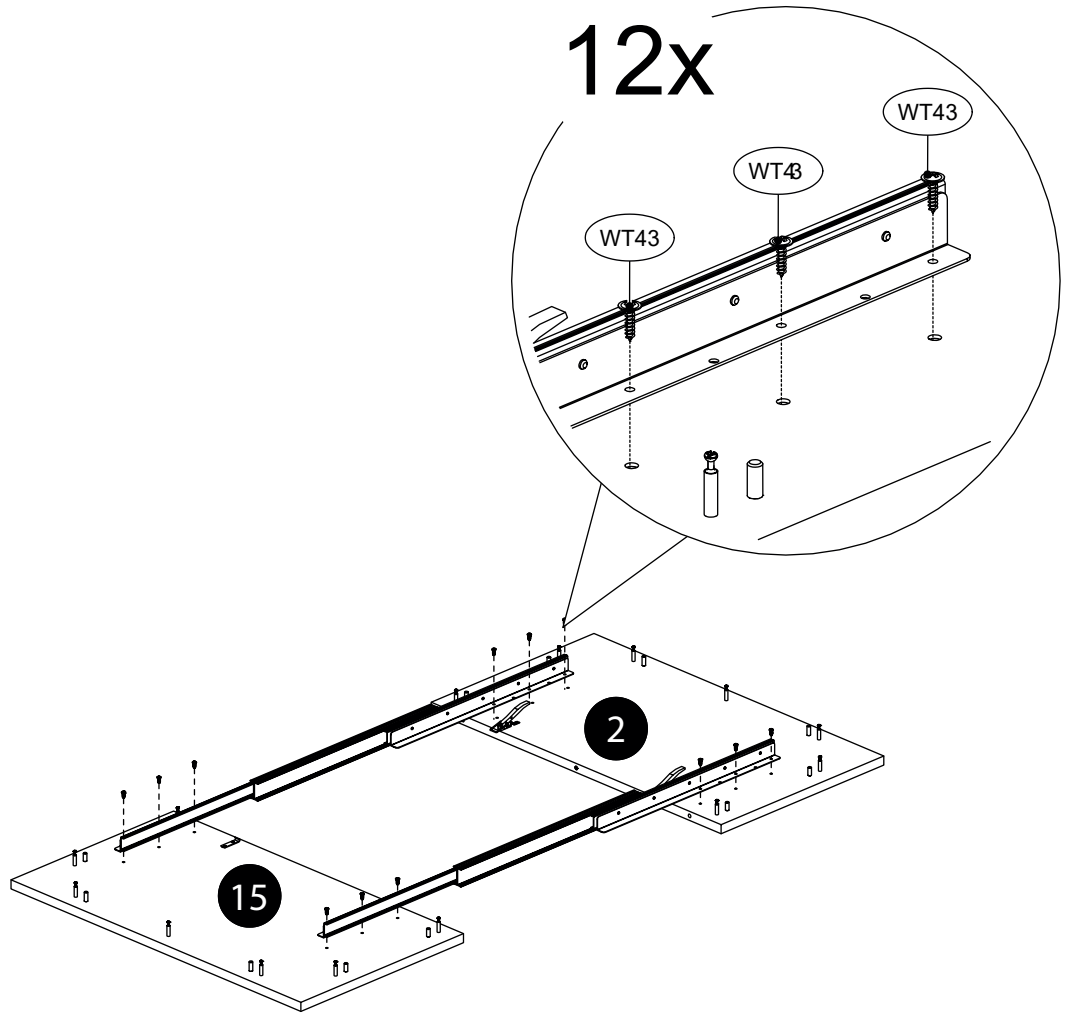

35.

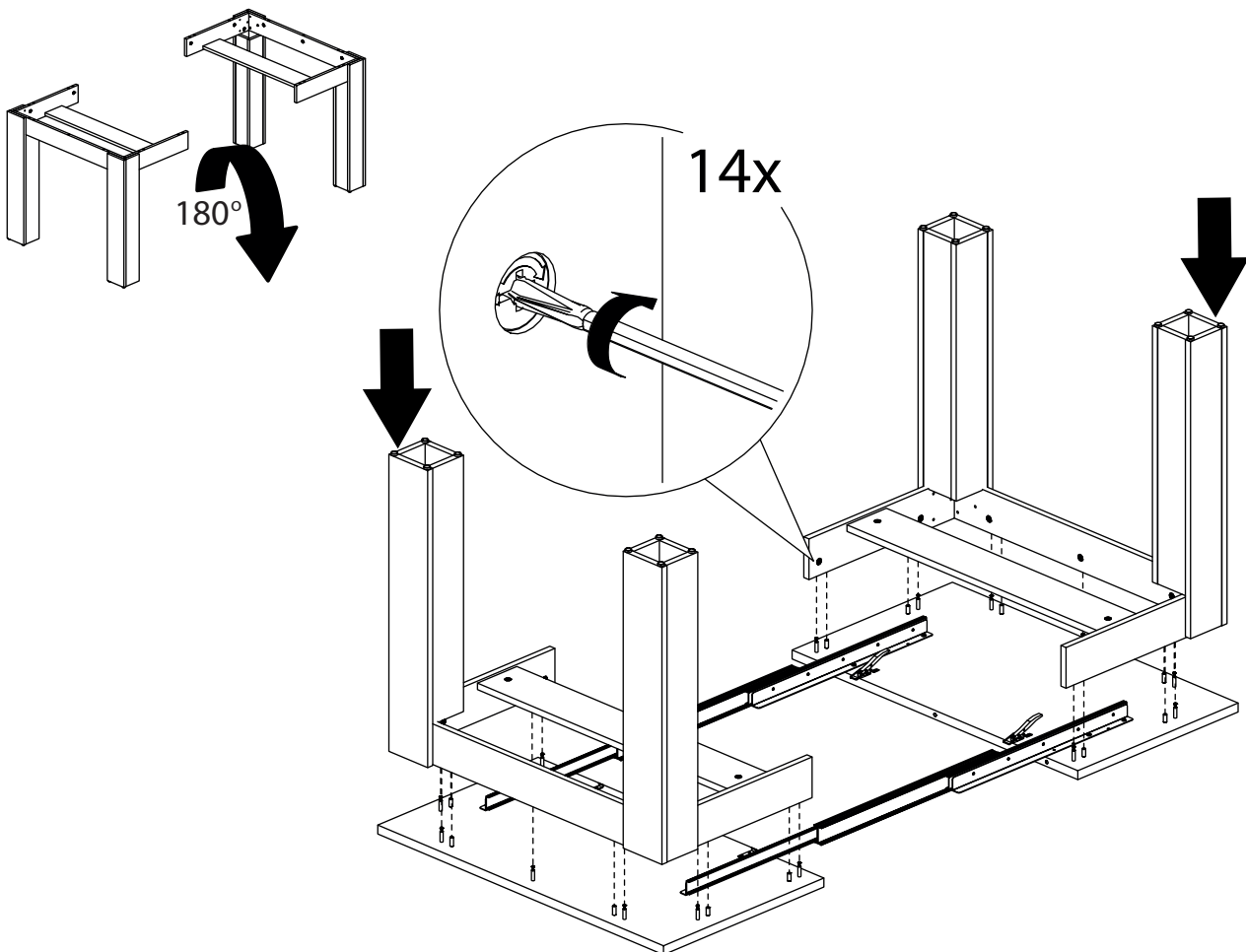

36.

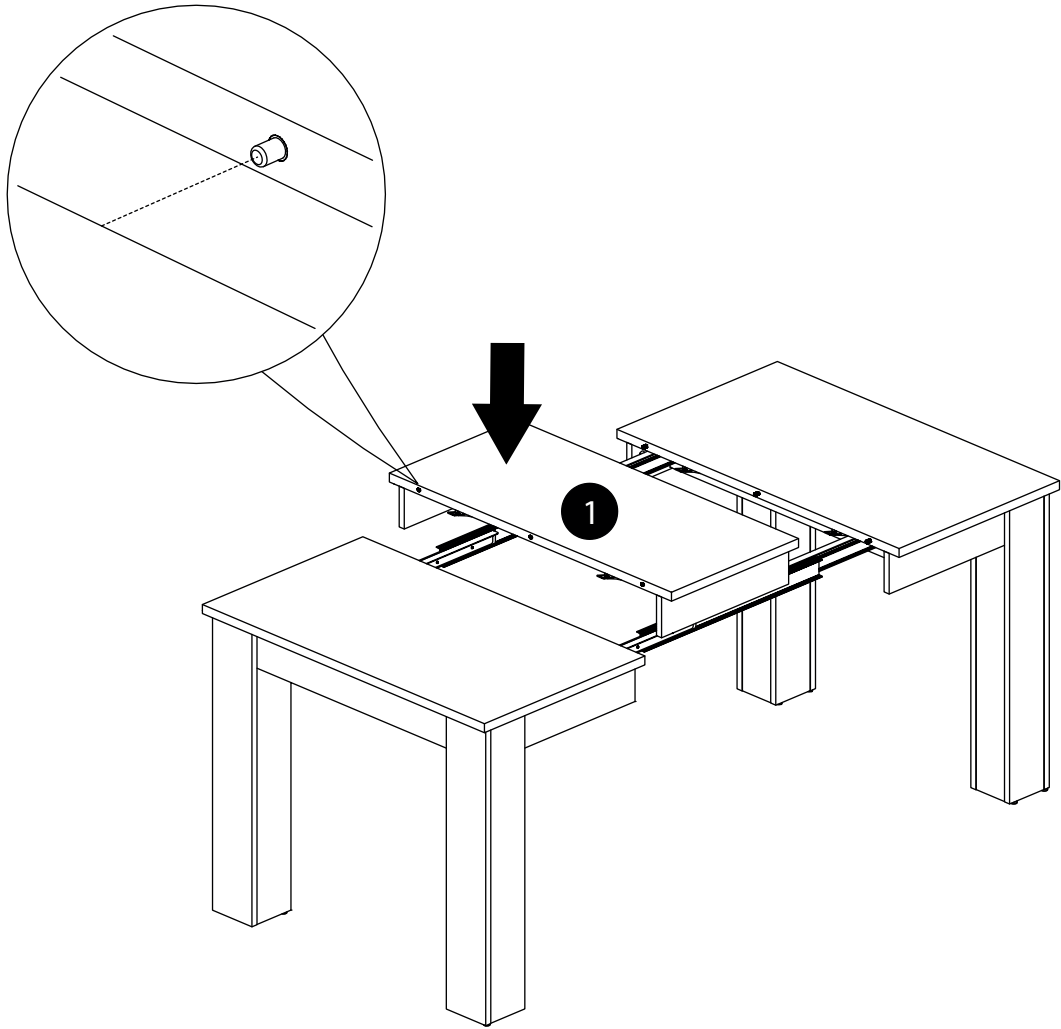

37.

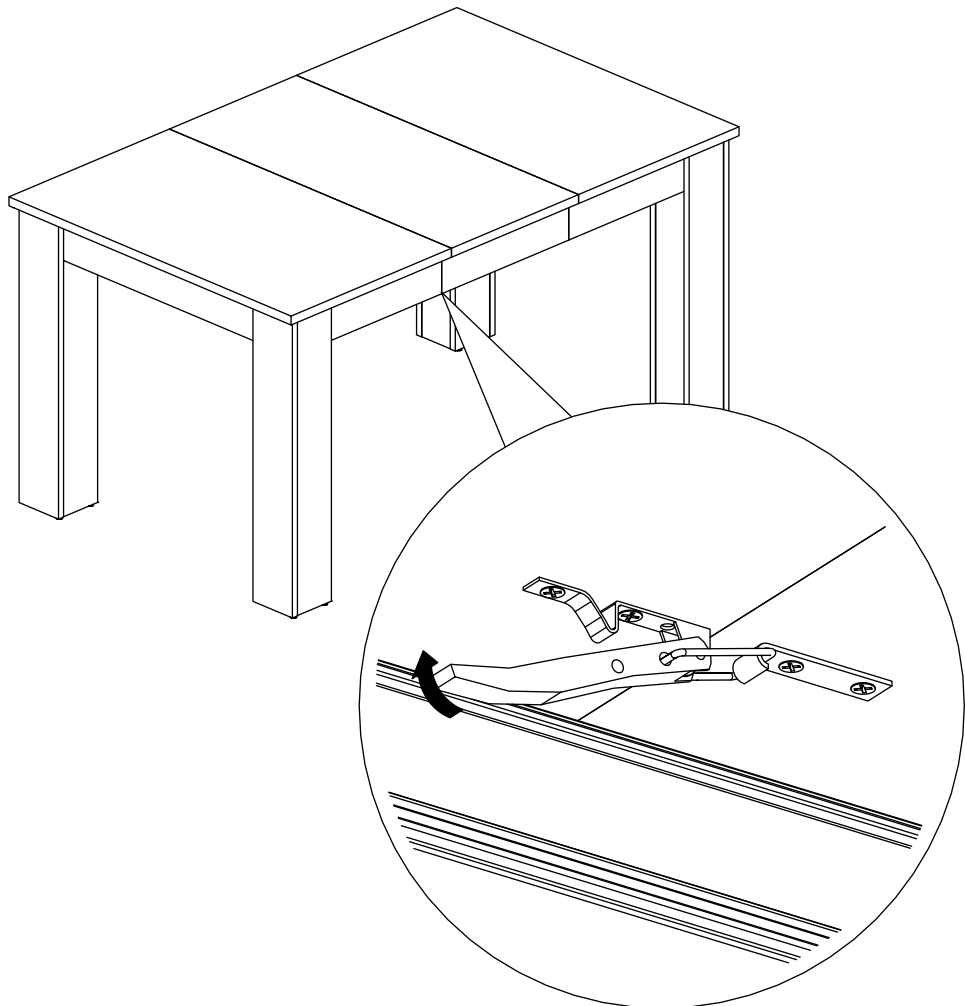

38.

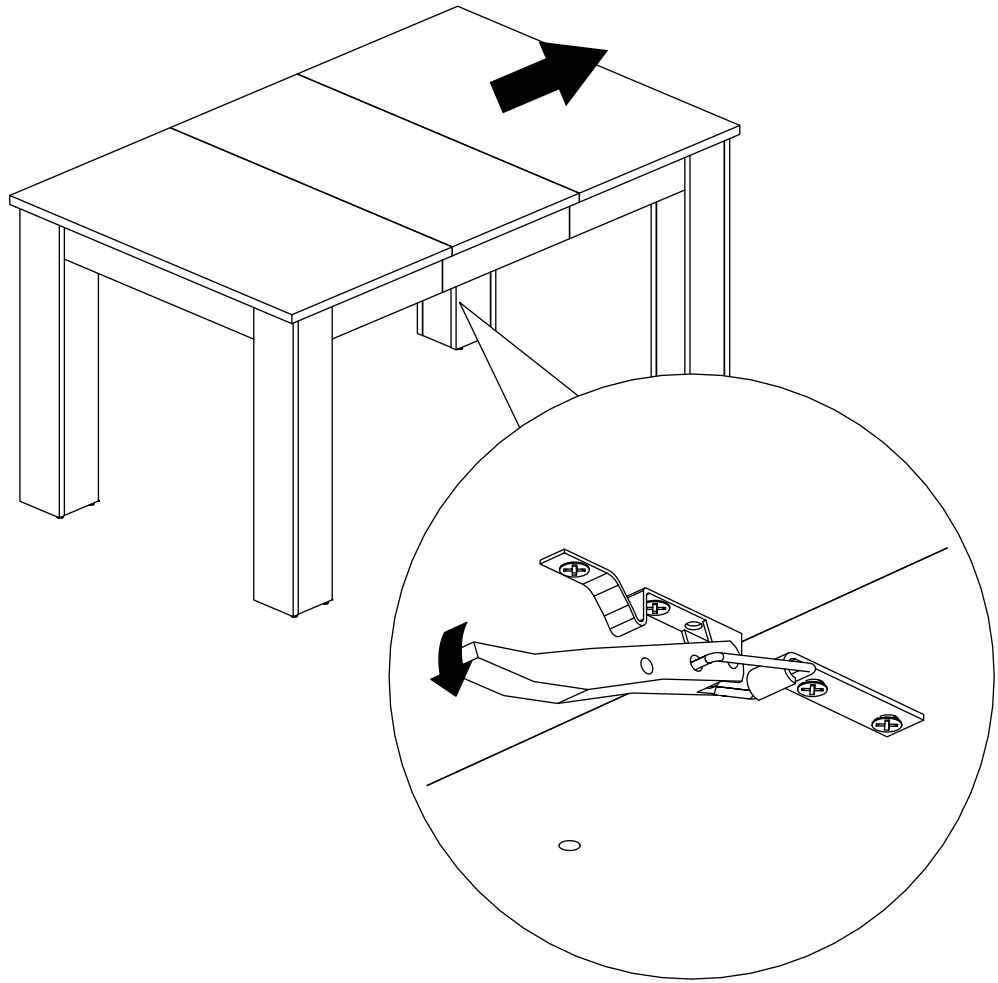

39.

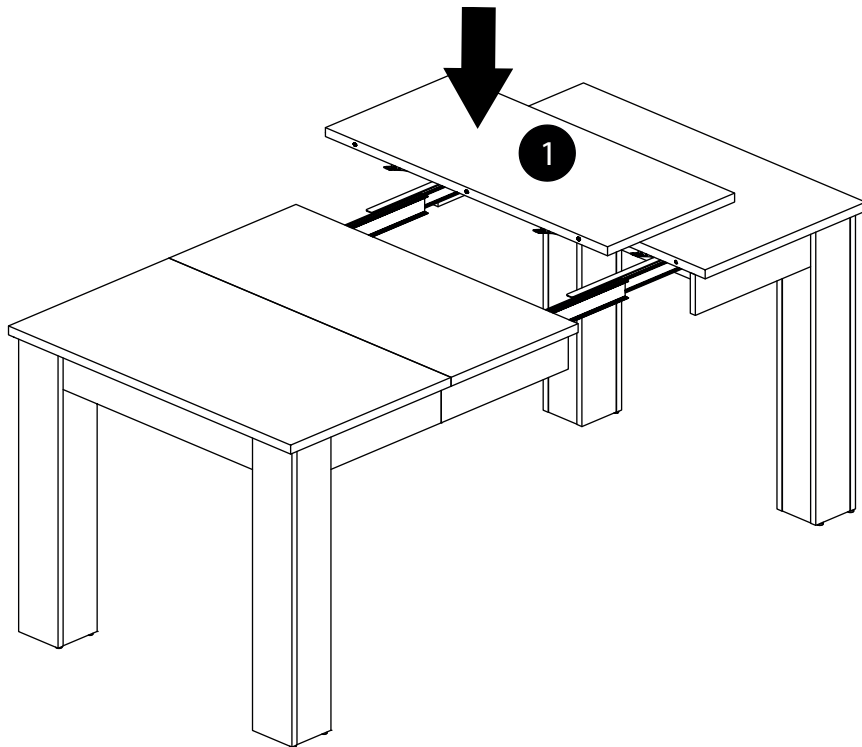

40.

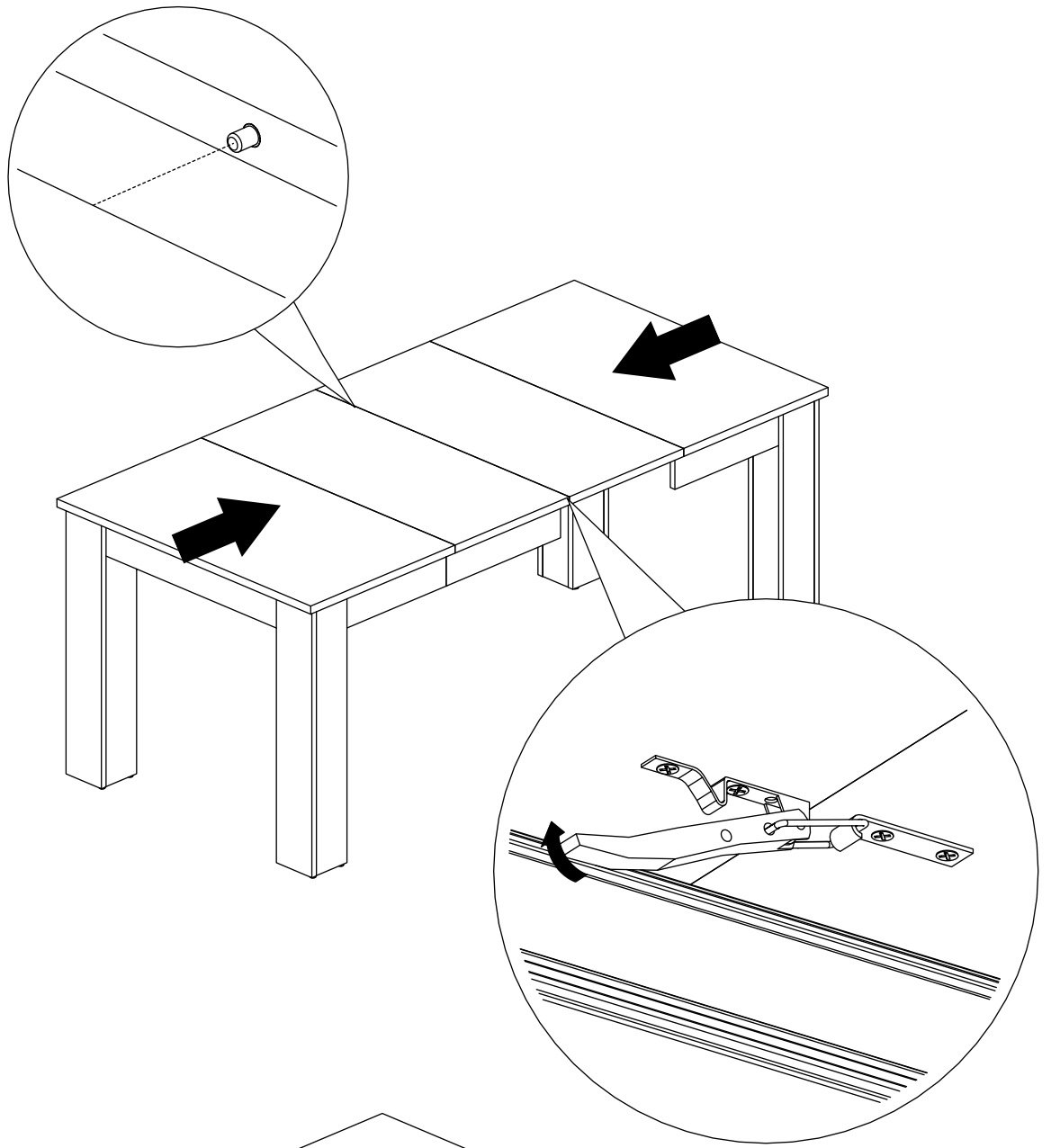

41.

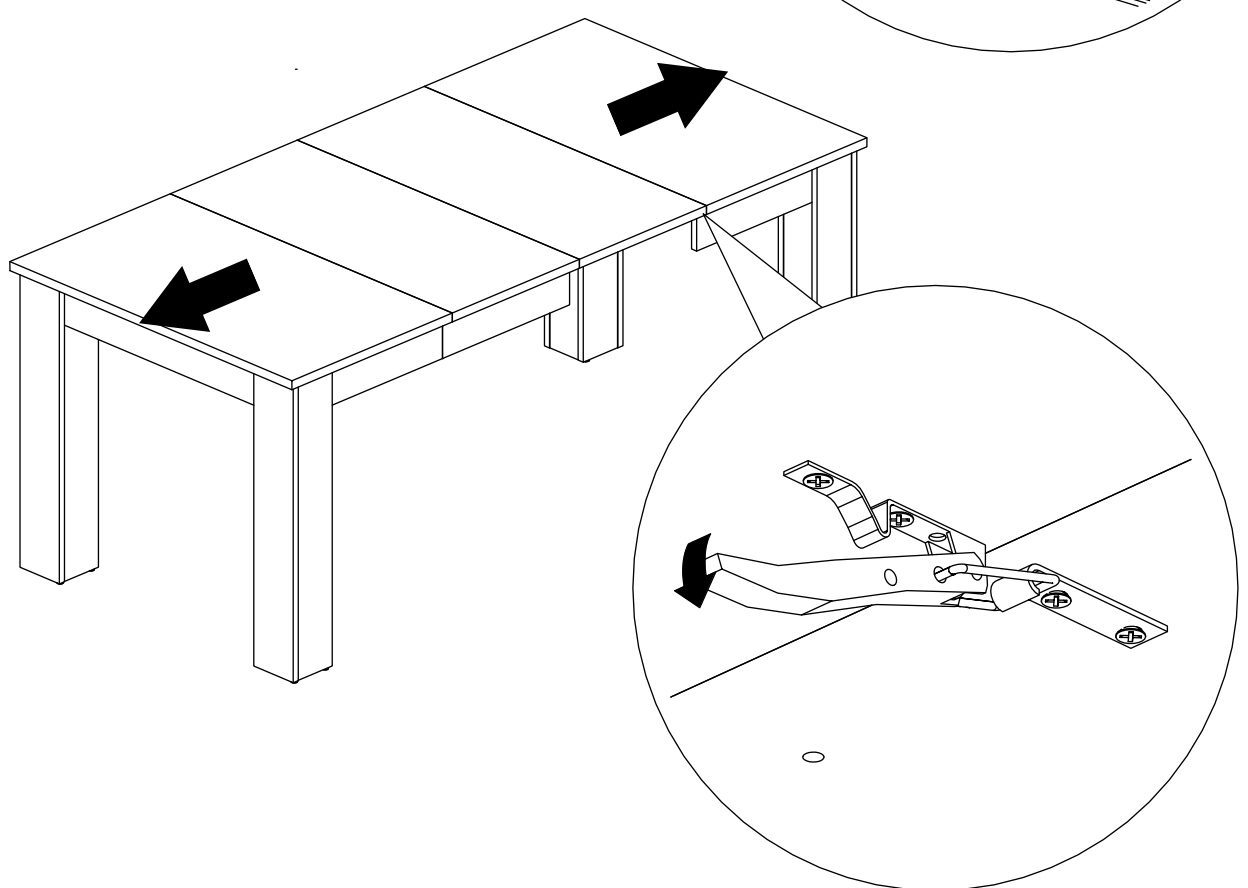

42.

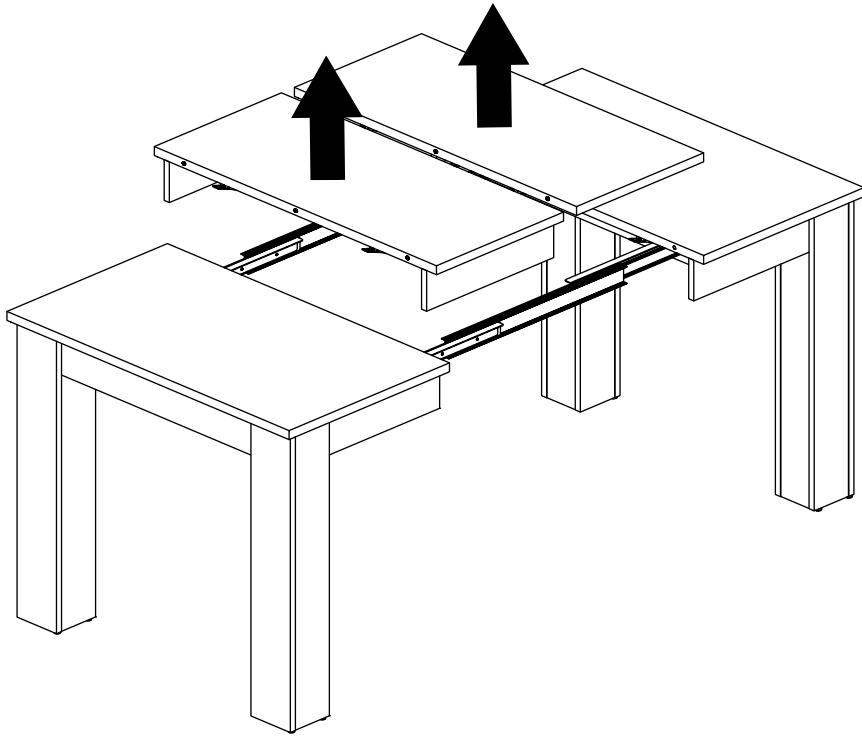

43.

