

ROCK

1826-131-35
 1826-131-48
 1826-131-49

131

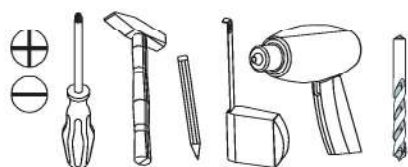
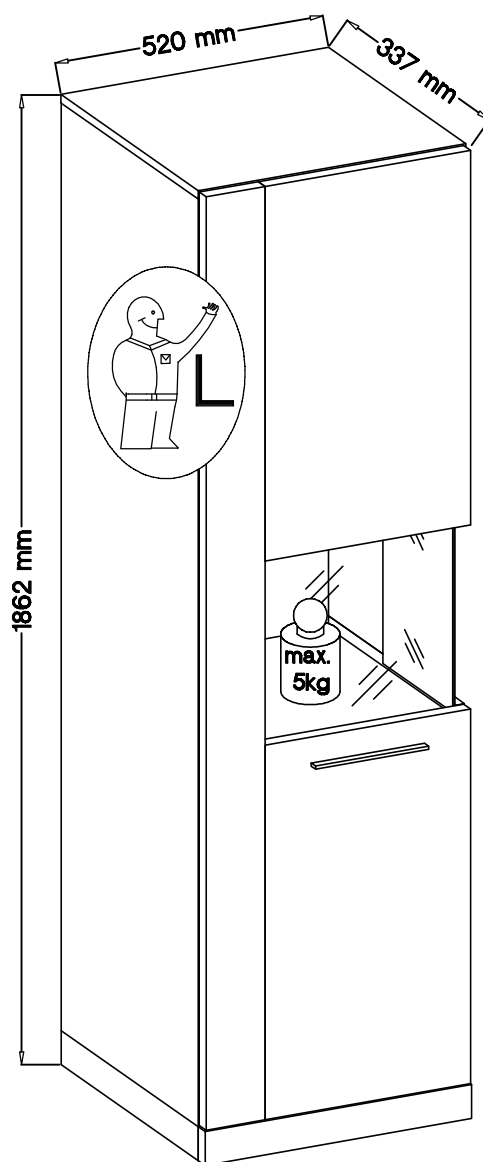
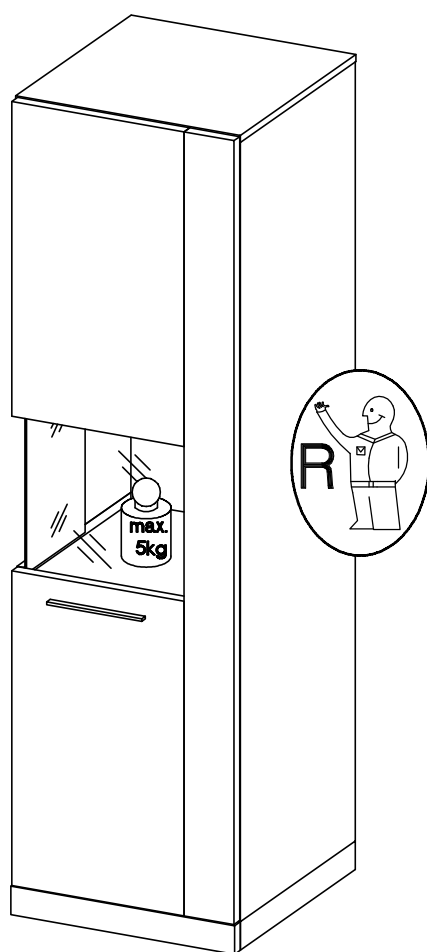
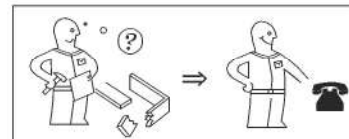
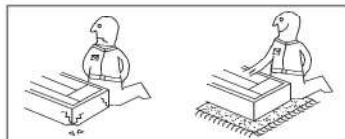
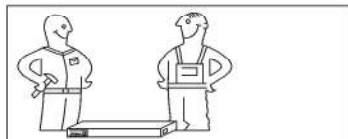

festziehen / tighten / Sareniero / serrer / stringere / utáhout / vastrekken / zategnuti / stáhnúre / zwiázac / zacišnač szorosan meghúzni / pevne dotiahnut / trdno pritegniti / затянуть / dra át / tjar / Sikin



eindrücken / press in / enfoncer / wcisnać ribattere / zatačit / Вкарайте / indrukken beňyomni / stlačit / vtisniti / tryk in introducere prin apăşare / вдвигать / empujar / țeri bastin



ausmessen / measure / mesurer / măsurare / ometen / izmeriti / miara / kimémi / izmeriti / măsurare / измерить / změřit / Измерете / mät upp / zmierzyc / medir / Ölçün



drücken / press / presser / stiknout / Наиснете / vtisniti / nasinac / drukken / pritisnuti / nacisnac / pritisniti / намаць / (мед)гнутити / apăşare / tryck fast / nacisnač / presionar / Bastinn



einschlagen / hammer in / beverni / sla in frapper au marteau / infossare / Zabit / zaražt / Набейте / zabiti / vbic / introducere prin bătaie / забить / zatlout / clavar / țeri vurun



Drehen - wenden / przekreć - odwrócić / Keren - omdraalen / Girare - Ruotare / Okrenuti / Retourner - reverser / Turn over - turn around / Otocle - obrátte / Заверте - обьърете / Obrnite list / Intoarceți - rotii / Vrid runt - vänd / прокрутить - повернуть / otóčit - obrátit / elforgathi - megfordítani / Girar / Çevirin

ROCK

1826-131-35
 1826-131-48
 1826-131-49

131

D Unser Direktservice für Beschlagteile
 Sollte Ihnen ein Beschlagteil fehlen, können Sie diese Servicekarte direkt an die untenstehende Adresse mailen. Wir können allerdings nur Beschlagteile auf diesem Wege verschicken. Sollten Sie eine andere Beanstandung an Ihrem Möbelstück haben, so wenden Sie sich bitte direkt an Ihr Möbelhaus.

GB Our direct order service for fitting
 If a fitting part is missing, you can e-mail this service card directly to the address below. However, we can only send fitting parts in this way. If you have any other cause for complaint concerning your item of furniture, please contact your furniture store directly.

CZ Naše přímé služby pro kování
 Chybí li vám nějaký díl z kování, můžete tuto servisní kartu odeslat e-mailem přímo na níže uvedenou adresu. Touto cestou však můžeme zoslat jen díly kování. Pokud byste reklamovali jiný díl nábytku, obraťte se přímo na svého prodejce nábytku.

F Bien étudier la notice de montage
 Si il vous manque une ferrure, veuillez envoyer directement la présente carte service à l'adresse e-mail indiquée ci-dessous. Cependant, ceci nous permet uniquement d'envoyer des ferrures. Pour tout autre type de réclamation concernant votre meuble, veuillez contacter directement votre magasin d'ameublement.

I Il nostro servizio diretto per l'ordine della ferramenta
 Qualora Vi dovesse mancare un pezzo di fissaggio, allora Vi preghiamo di inviare questa carta di servizio immediatamente all'indirizzo sottostante. Possiamo inviare i pezzi di fissaggio solamente per mezzo di questo procedimento. Qualora doveste avere qualche altra reclamazione in merito al mobile, allora Vi preghiamo di rivolgerVi direttamente al Vostro Negozio di mobili.

BG Нашата директна услуга за обнова
 Ако липсват части от комплекта, потърнете настоящата сервисна карта и ни я изпратете на e-mail адреса, посочен по-долу. По този начин можем да доставяме само гисоващи елементи от обнова. Ако установите други дефекти по мебелите, Ви съветваме да се обърнете към мебелната къща/магазин, от който сте закупили стоката.

NL Onze directservice voor losse onderdelen
 Wanneer er een onderdeel ontbreekt, kunt u deze servicekaart direct aan ons toezenden e-mailadres sturen. Wij kunnen langs deze weg slechts afgevoerde beslagdelen versturen. Mocht u een ander probleem aan uw meubel hebben, verzoeken wij u contact op te nemen met uw meubeldealer.

PL Nasz bezpośredni serwis części montażowych
 Jeżeli brakuje części koniecznych do montażu, prosimy o przesłanie nam niniejszej karty serwisowej na niżej podany adres e-mailowy. W ten sposób możemy przesłać Państwu tylko brakujące części. W przypadku innych reklamacji dotyczących mebla, prosimy zgłosić się do salonu meblowego, w którym został dokonany zakup.

HR Servis za okove
 U slučaju da nedostaje neki od dijelova molimo vas da na dolje navedenu mail adresu pošaljete ovaj servisni obrazac. Na ovaj način mogu se dostaviti samo okovi. U slučaju da imate dodatne prigovore vezane uz komad namještaja molimo vas da se obratite izravno trgovini namještaja gdje je isti kupljen.

HU Direktszolgáltatunk vasalatók esetén
 Ha hiányzik egy vasalató, ezt a kártyát közvetlenül elküldheti az alább található címre. Azonban csak vasalatókat tudunk így küldeni. Amennyiben másfajta reklamációt áll ferm bútorárbaját illetően, forduljon közvetlenül a boltiárházhoz.

SK Náš priamy servis pre časti kovania
 Ak by Vám chýbala nejaká časť kovania, môžete poslať túto servisnú kartu poslať e-mailom na nižšie uvedenú adresu. Diely kovania vieme poslať iba týmto spôsobom. Ak by ste mali inú reklamáciu ohľadom Vášho nábytku, obráťte sa priamo na Vašu predajňu nábytku.

SLO Naše direktne uslužne storitve za okovje
 Če vam manjka kakšno okovje, lahko to servisno kartico pošljete po e-pošti direktno na spodnji naslov. Po tej poti vam lahko pošljemo samo okovje. Če želite reklamirati kakšen drug del pohištva, se obrnite neposredno na vašo trgovino pohištva.

RO Service-ul nostru direct pentru feronerie
 În cazul în care vă lipsește o piesă de feronerie puteți să trimiteți direct acest card de service prin e-mail la adresa de mai jos. Noi nu putem expedia piese de feronerie decât pe această cale. Dacă aveți o altă reclamație referitoare la piesa de mobilier, atunci vă rugăm să vă adresați direct la magazinul dvs. de mobilier.

RUS Наш прямой сервис для поставки фурнитуры
 Если окажется, что Вам не хватает того или иного элемента фурнитуры, Вы можете отправить сервисную карту по факсу непосредственно на нижеприведенный адрес электронной почты. Однако, таким образом мы можем переслать лишь фурнитуру. Если же у Вас возникнут иные претензии относительно приобретенной мебели, пожалуйста, обращайтесь непосредственно в организацию, осуществившую продажу.









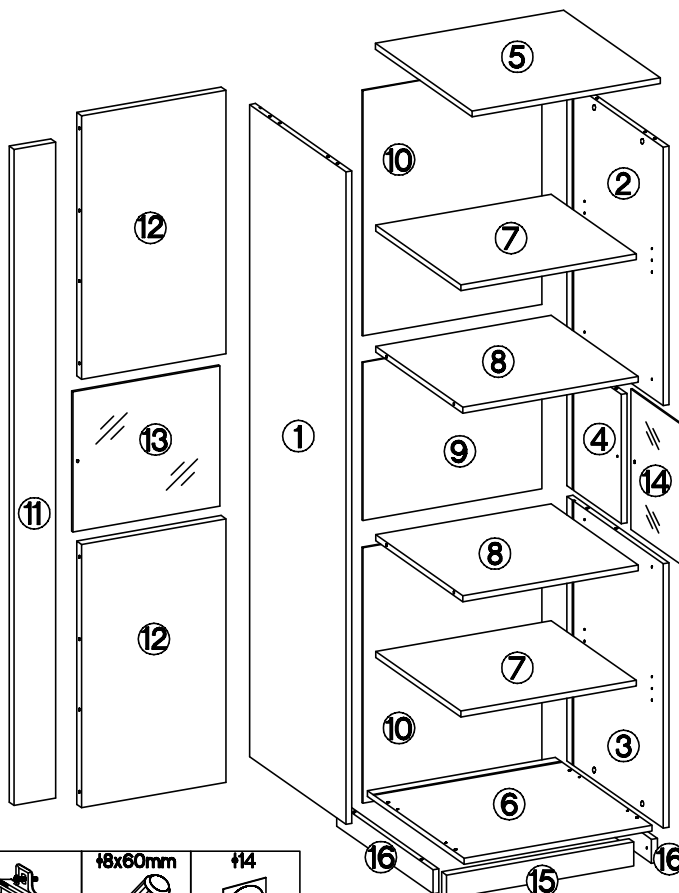

































S Vår direktservice för beslagsdelar
 Om du saknar en beslagsdel kan du skicka detta servicekort direkt till e-postadressen som anges nedan. Tänk på att detta är den enda möjligheten att skicka beslagsdelar till dig. Om du vill reklamera din möbel av en annan anledning måste du kontakta ditt möbelhus direkt.

ES Nuestro servicio directo para accesorios
 Si le falta algún accesorio, puede enviar esta tarjeta de servicio directamente a la siguiente dirección. No obstante, por este método solo podemos enviar accesorios. Si tiene alguna otra objeción sobre su mueble, consulte directamente con su mueblería.

TR Donatılar için doğrudan servisimiz
 Bir donatınız eksikse bu servis kartını doğrudan aşağıda bulunan adrese doğrudan mail yazabilirsiniz. Sadece bu yolla donatıları gönderebilirsiniz. Mobilyanızda başka şikayetleriniz varsa lütfen doğrudan mobilya satıcınıza danışın.

⑥, ⑦, ⑧ =  max. 5kg



 1 Ø7	 1 L9										
 1 Ø35/0mm	 1 Ø3.5x13mm	 4 H	 12 A2	 1 E13							
 4 L=192mm	 9 Ø4.0x27mm	 4 L	 8 L2	 1 Ø4.0x16mm	 2 T3	 6 J24	 8 Ø3.0x20mm	 6 Ø15x5mm			
 1 S17	 2 R1	 14 L	 8 L2	 4 P1	 2 T3	 6 J24	 8 P7	 6 F4			
 1 297,5	 2 L=20mm	 14 Ø15/12mm	 8 Ø8x30mm	 4 E	 2 Ø4.0x16mm	 6 Ø7/4mm	 8 J3	 6 0,05			
 16 1B	 16 D2	 16 C	 12 A	 16 E	 2 R11	 2 J7	 8 J3	 1 O11			

LKZ 80106

Grund der Beanstandung / Reason of the objection:

Möbelhaus / Furniture store:

Name / Name: Telefon / Telephone:



PLZ / postal code: Ort / City:

Strasse / Street:

Haus-Nr. / House No.: @E-Mail:

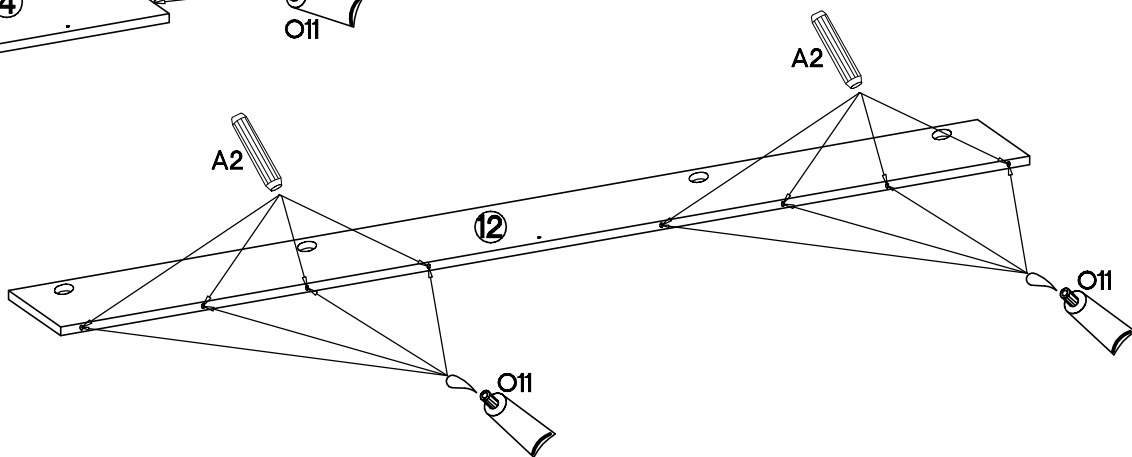
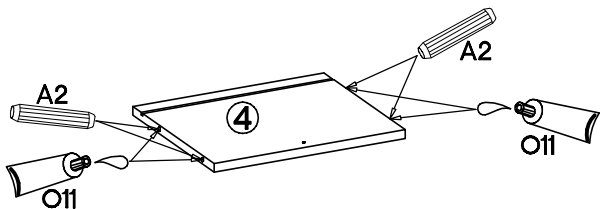
1



0,05  O11 1	#8x60mm  A2 12
---	--

2

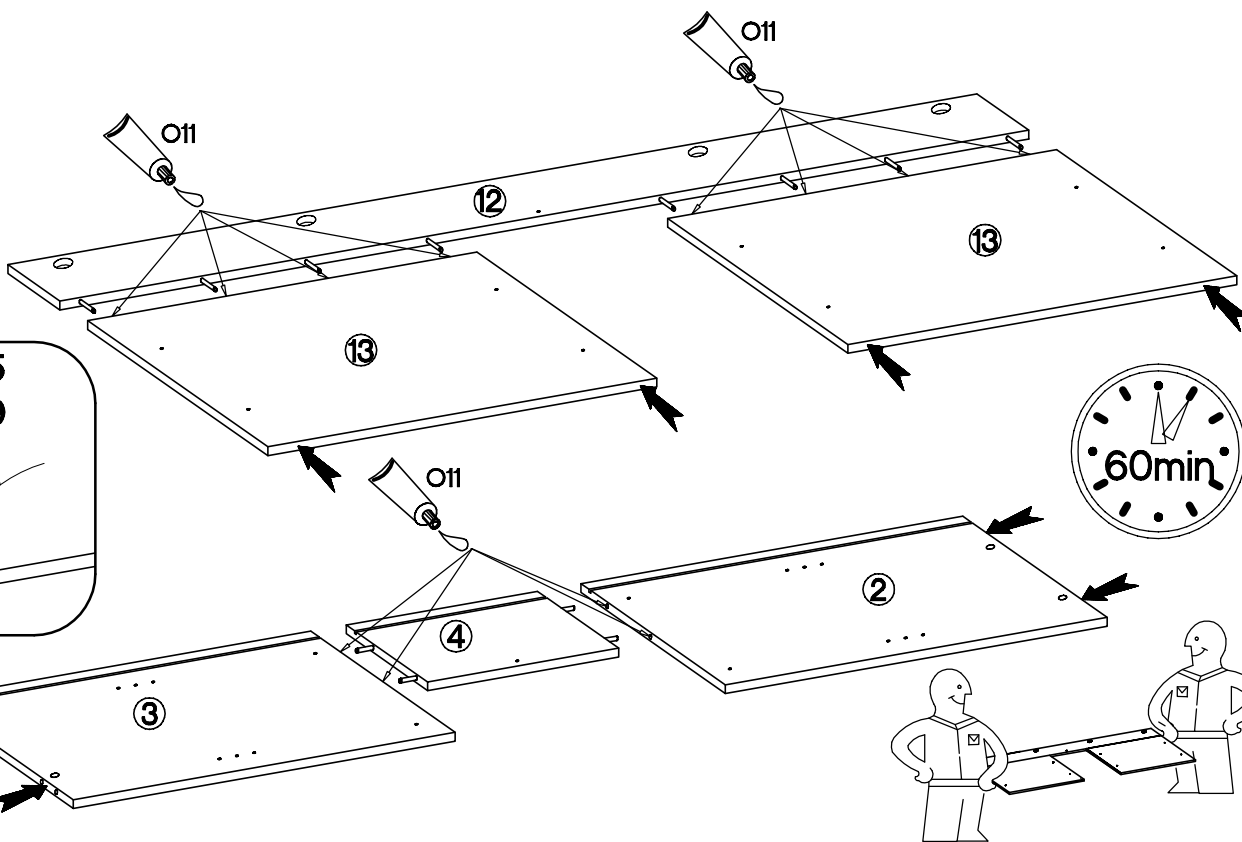

0,05  O11 1



1826-131-35
1826-131-49

60min

3

#35/0mm  G 4	#3.5x13mm  P5 8	 H 4
--	---	---

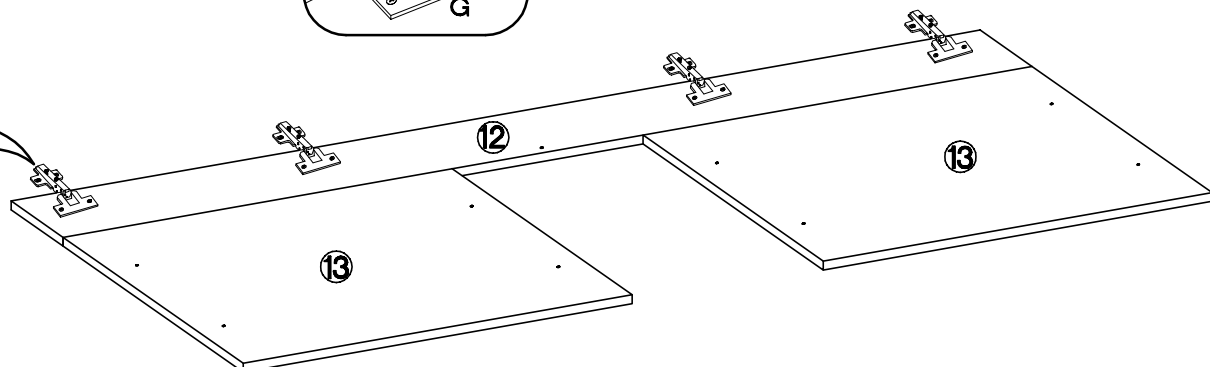
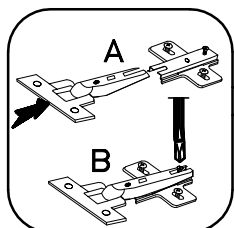
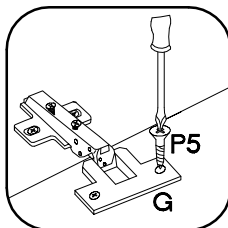

4

J24	J7	R11
4	1	1

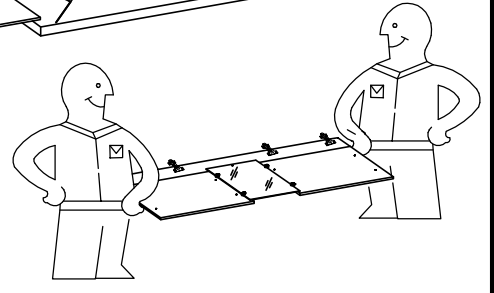
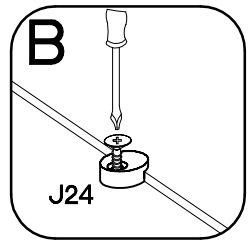
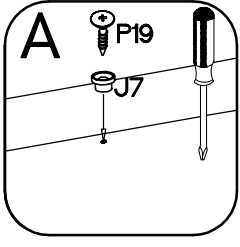
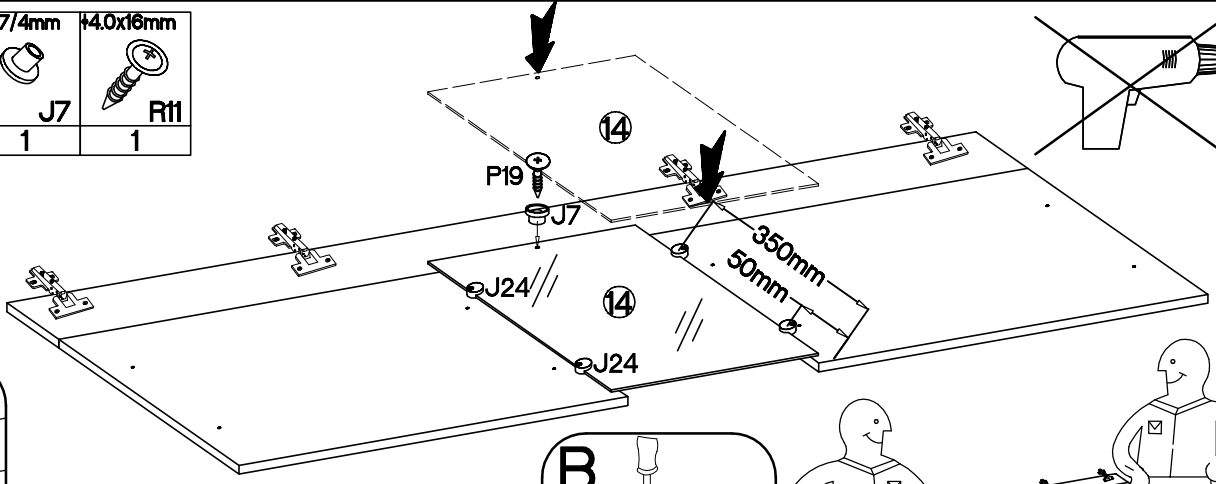

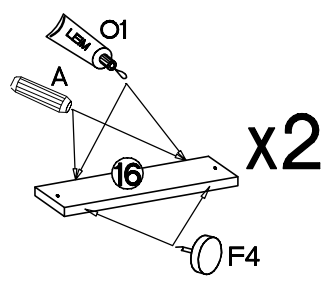
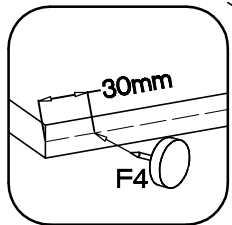
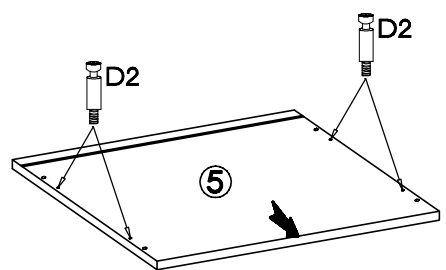
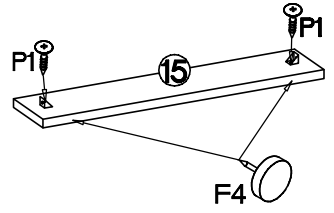
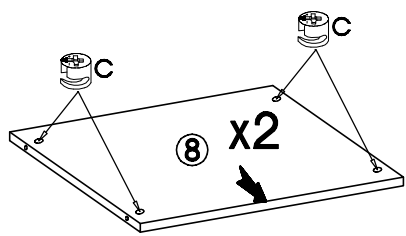
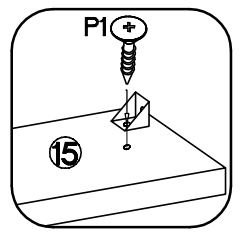
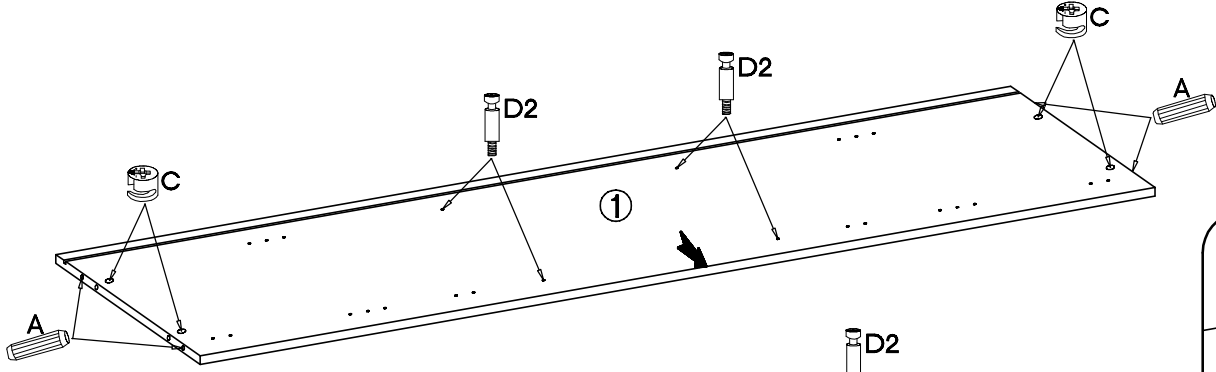
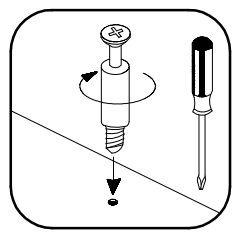
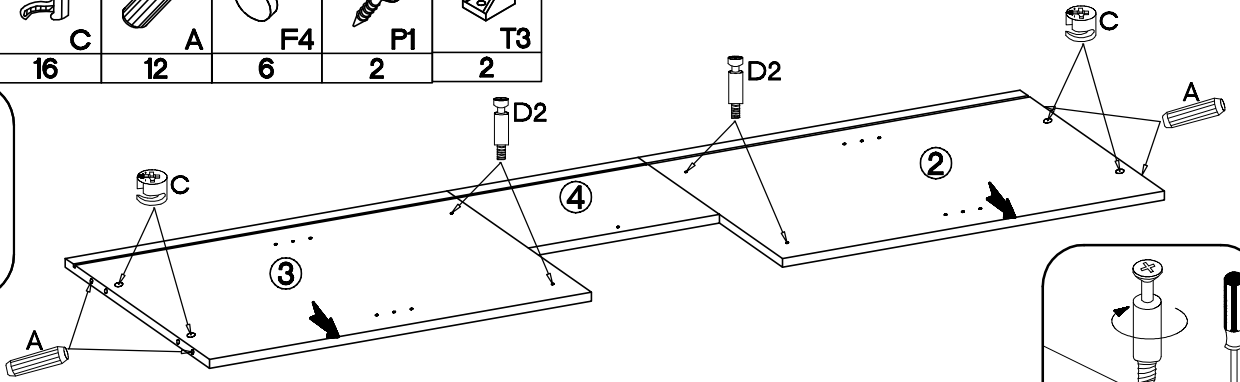
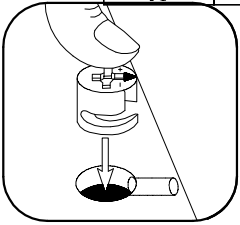

5

D2	C	A	F4	P1	T3
16	16	12	6	2	2



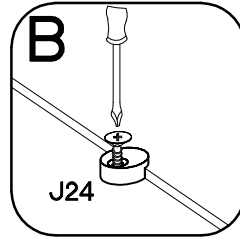
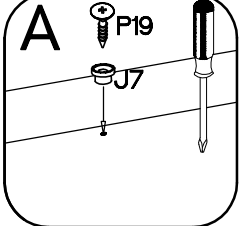
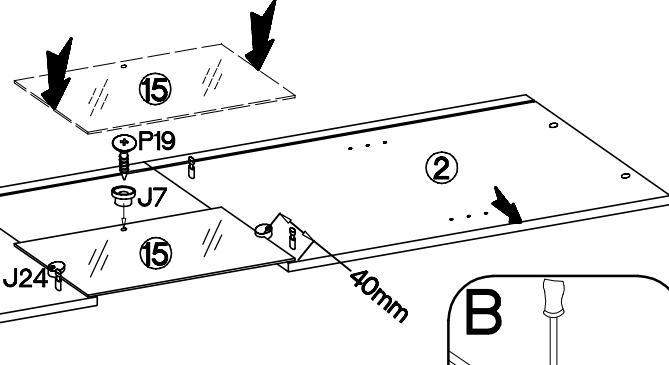
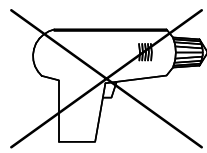

6

 J24 2	 J7 1	 P11 1
--	---	--



7

 P1 2	 O11 1
---	---

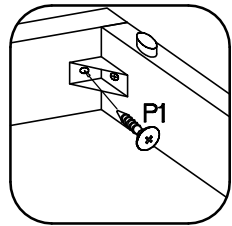
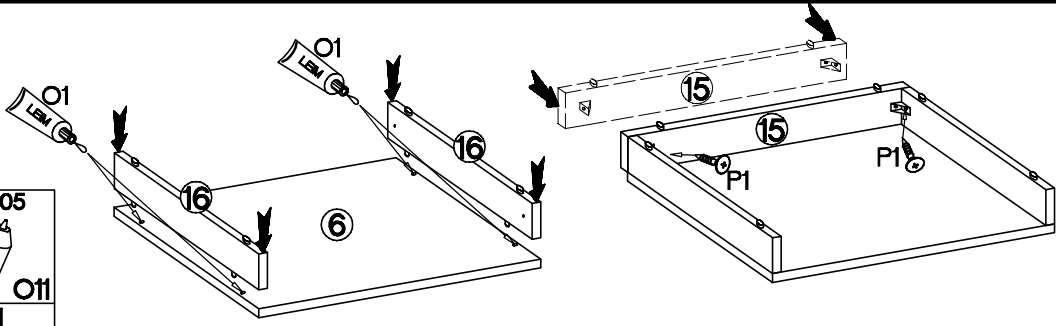

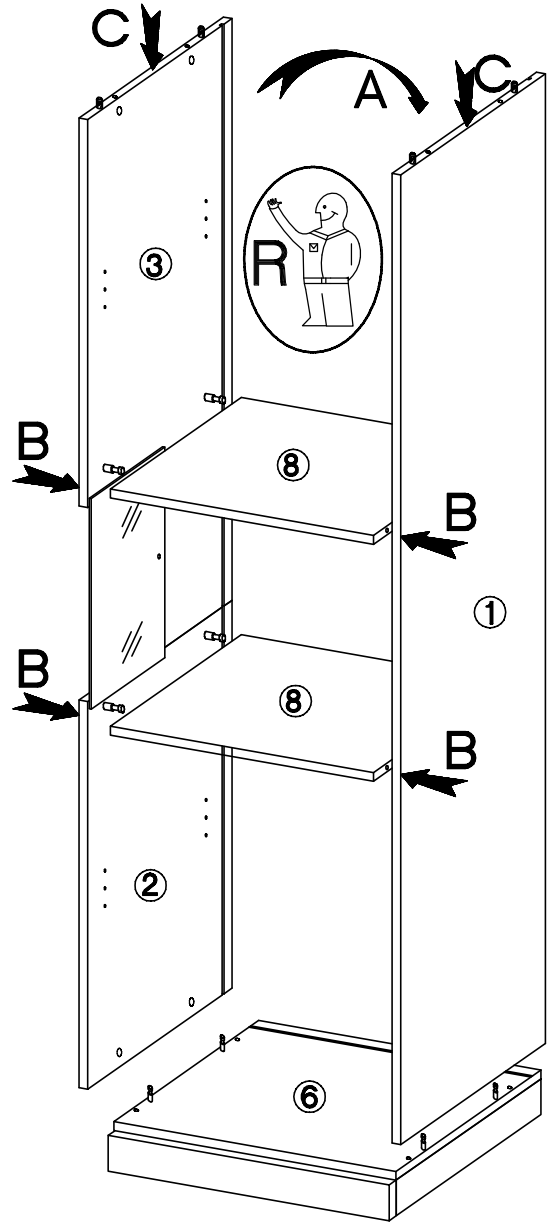
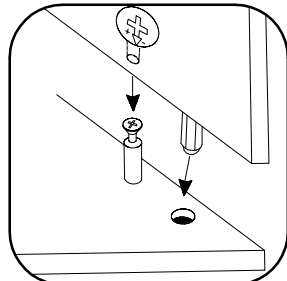
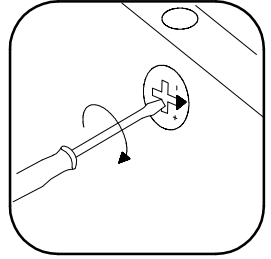
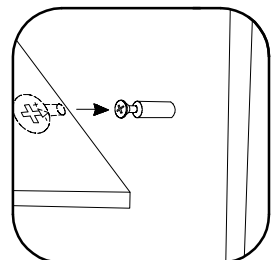
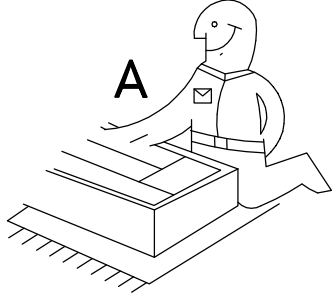
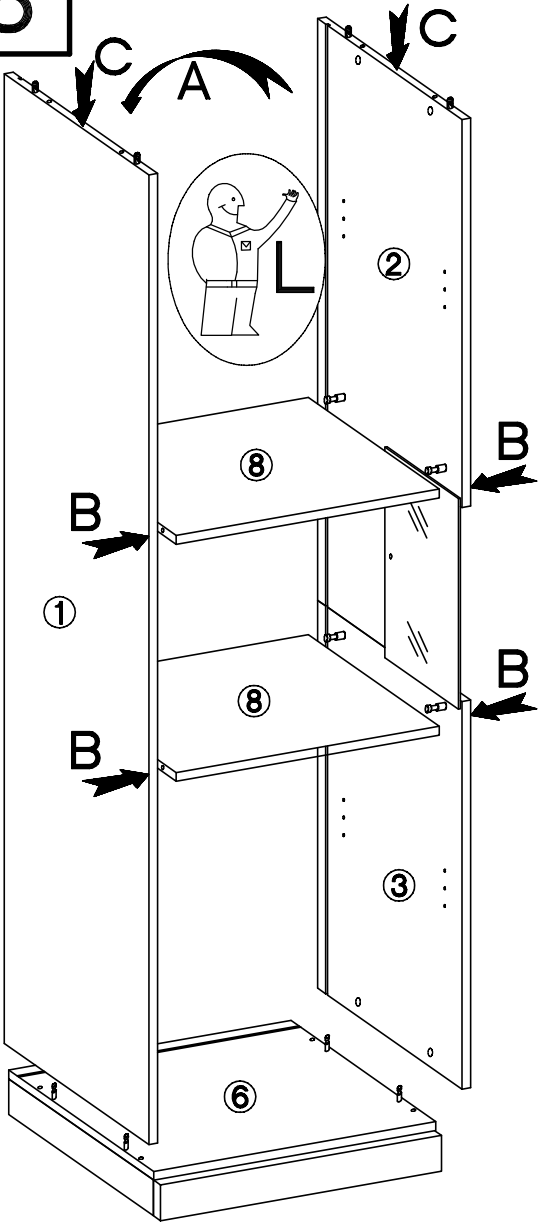

8



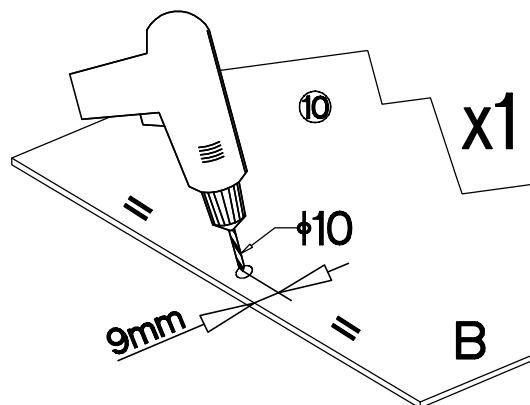
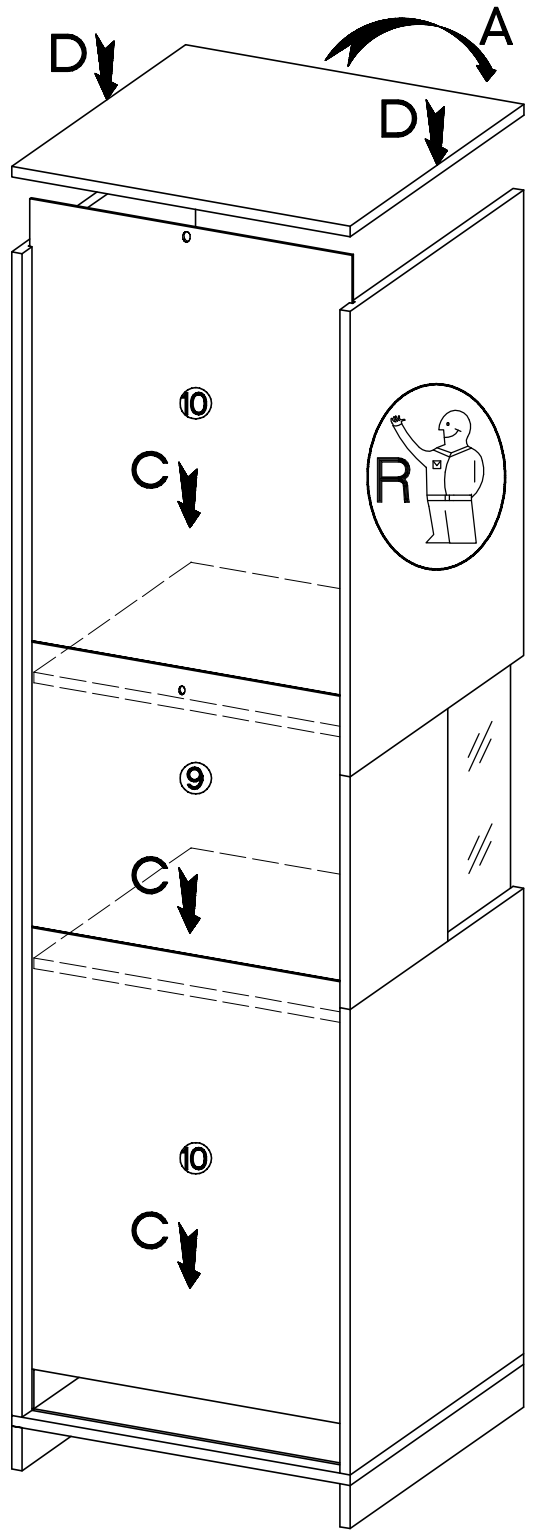
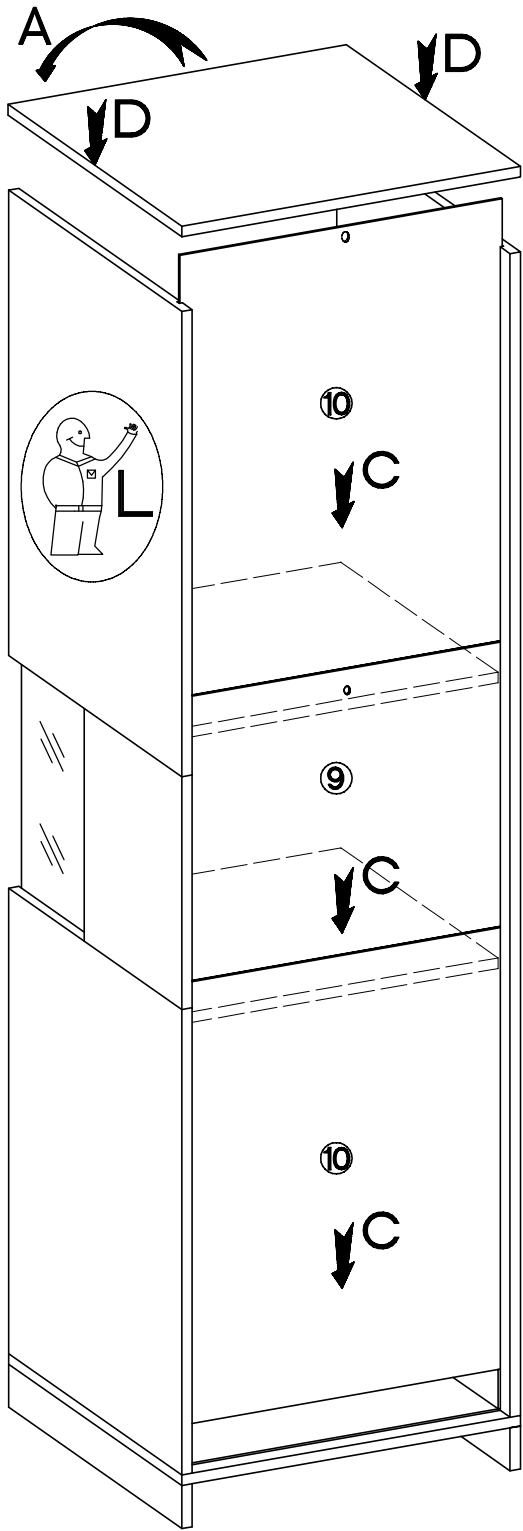



8

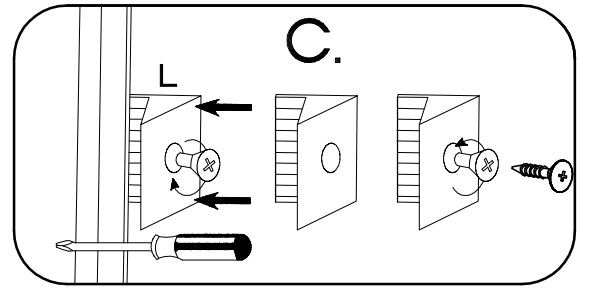
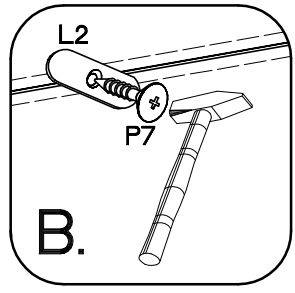
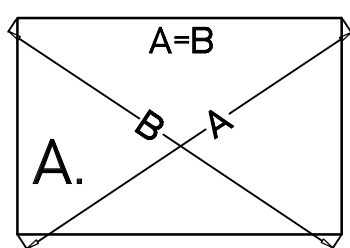
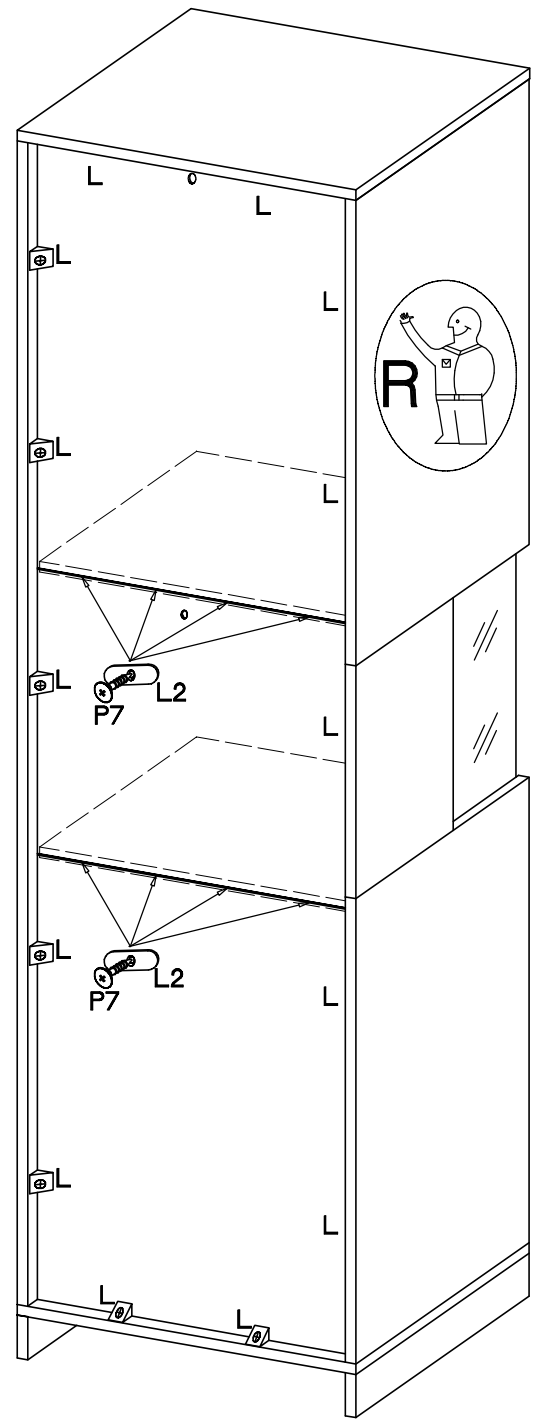
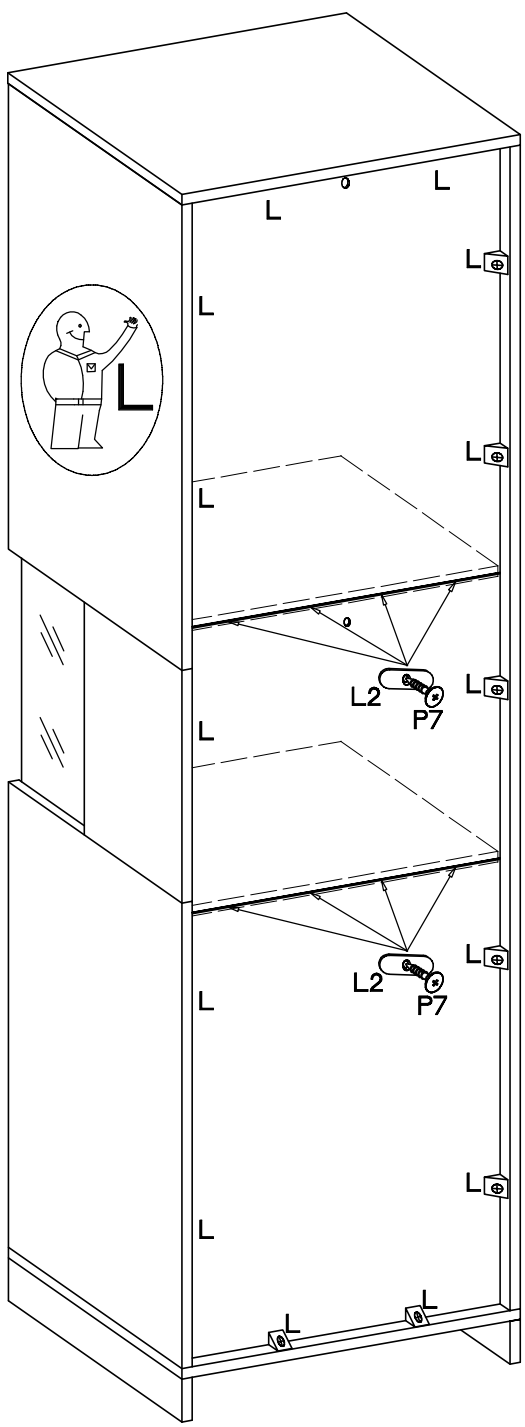

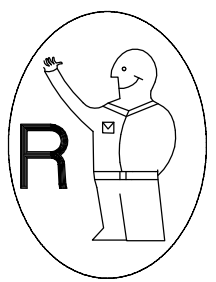
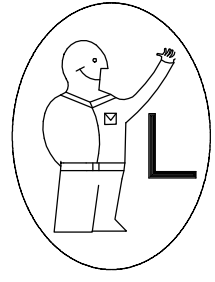
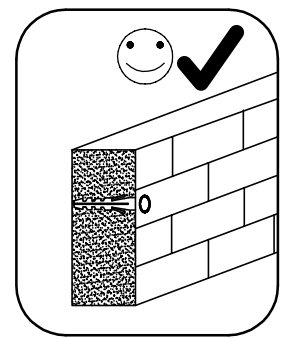
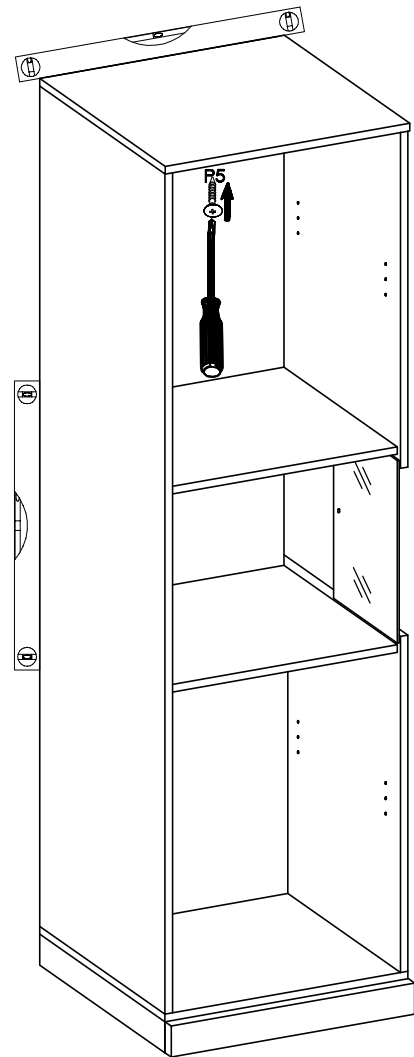
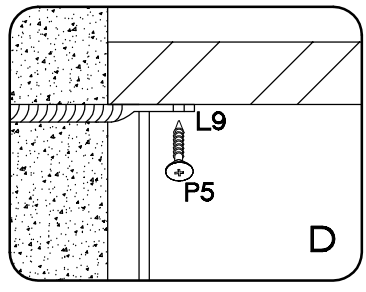
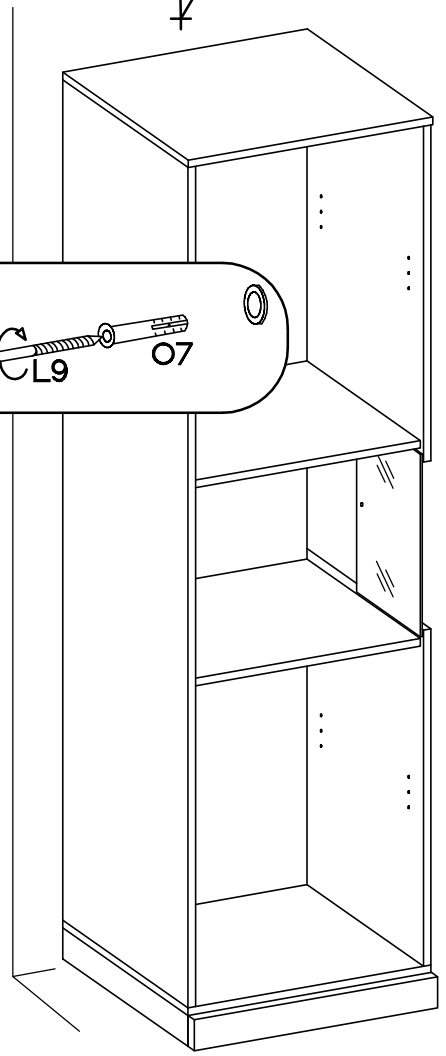
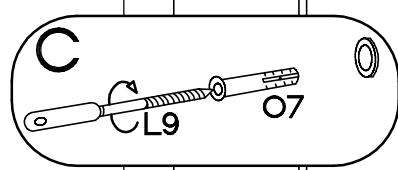
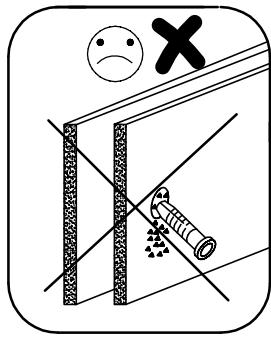
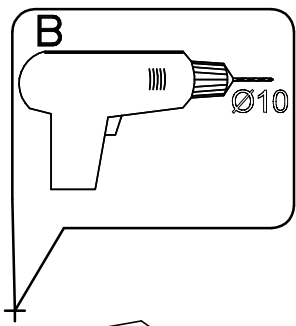
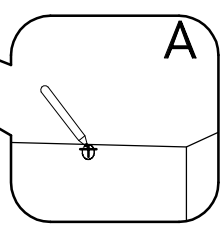
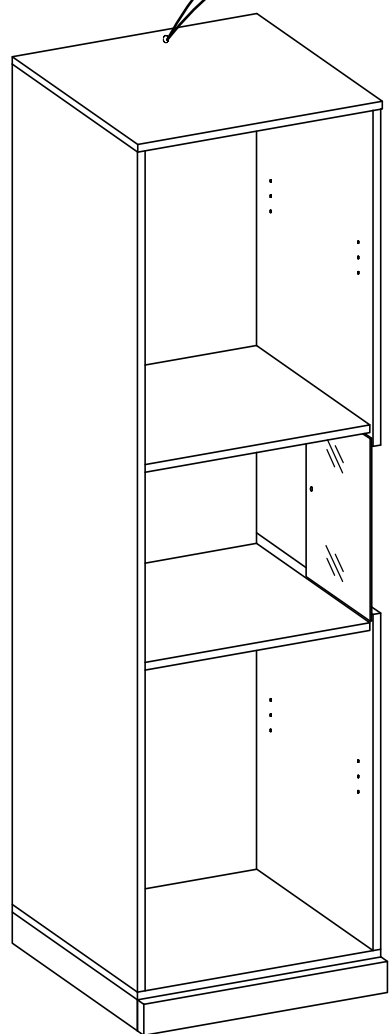

	#3.0x20mm		
L2		P7	L
8		8	14





		
#10x50mm	#3.5x13mm	
O7	L9	P5
1	1	1

11

L=192mm	4.0x27mm
	
S17	R1
1	2

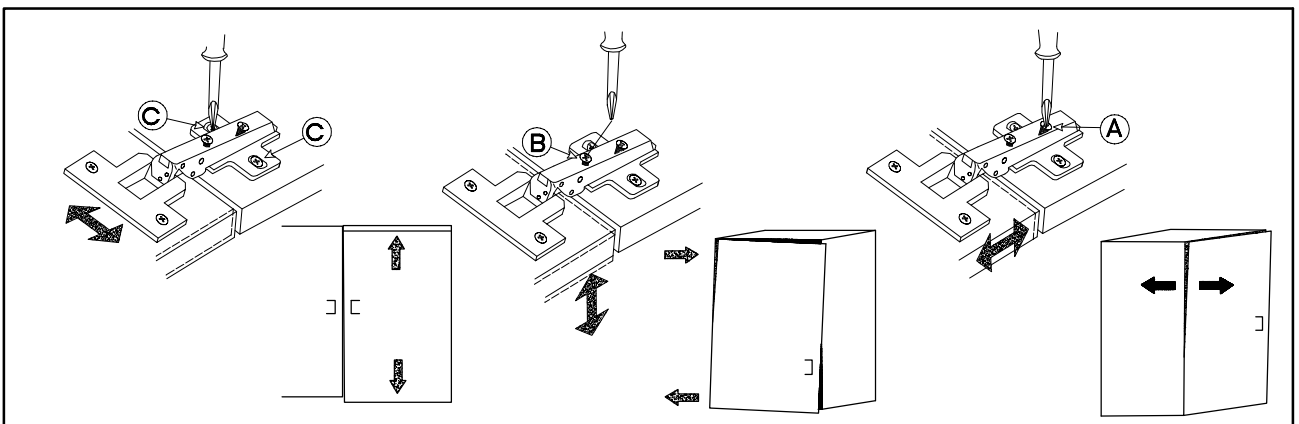
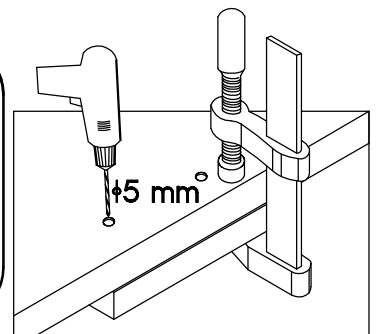
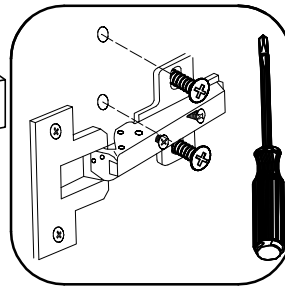
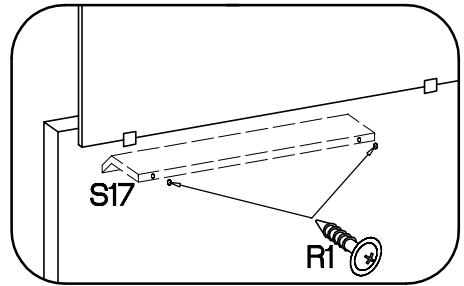
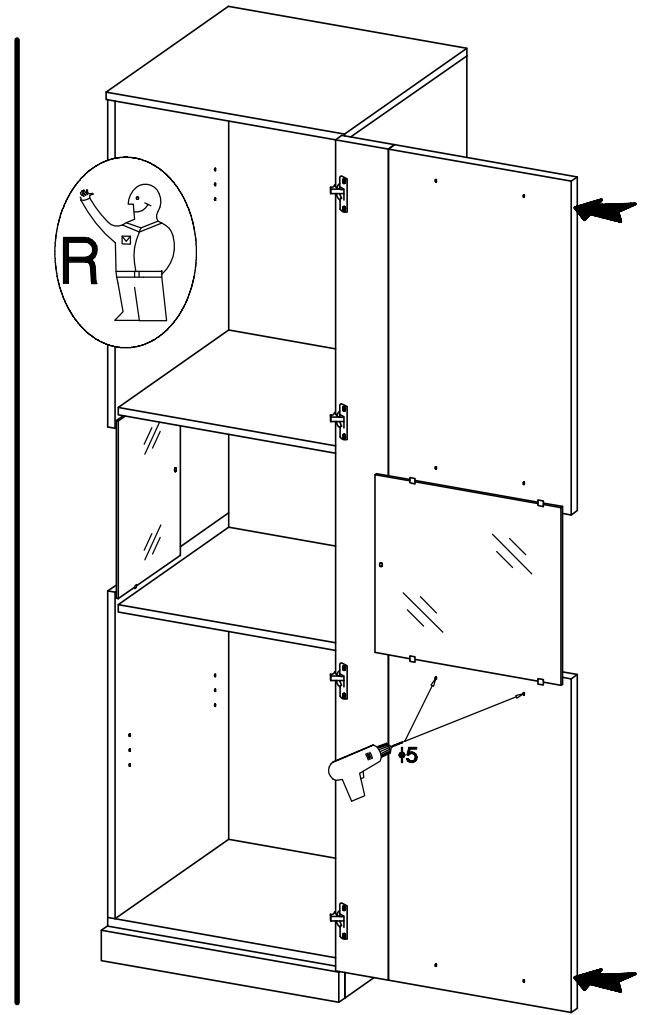
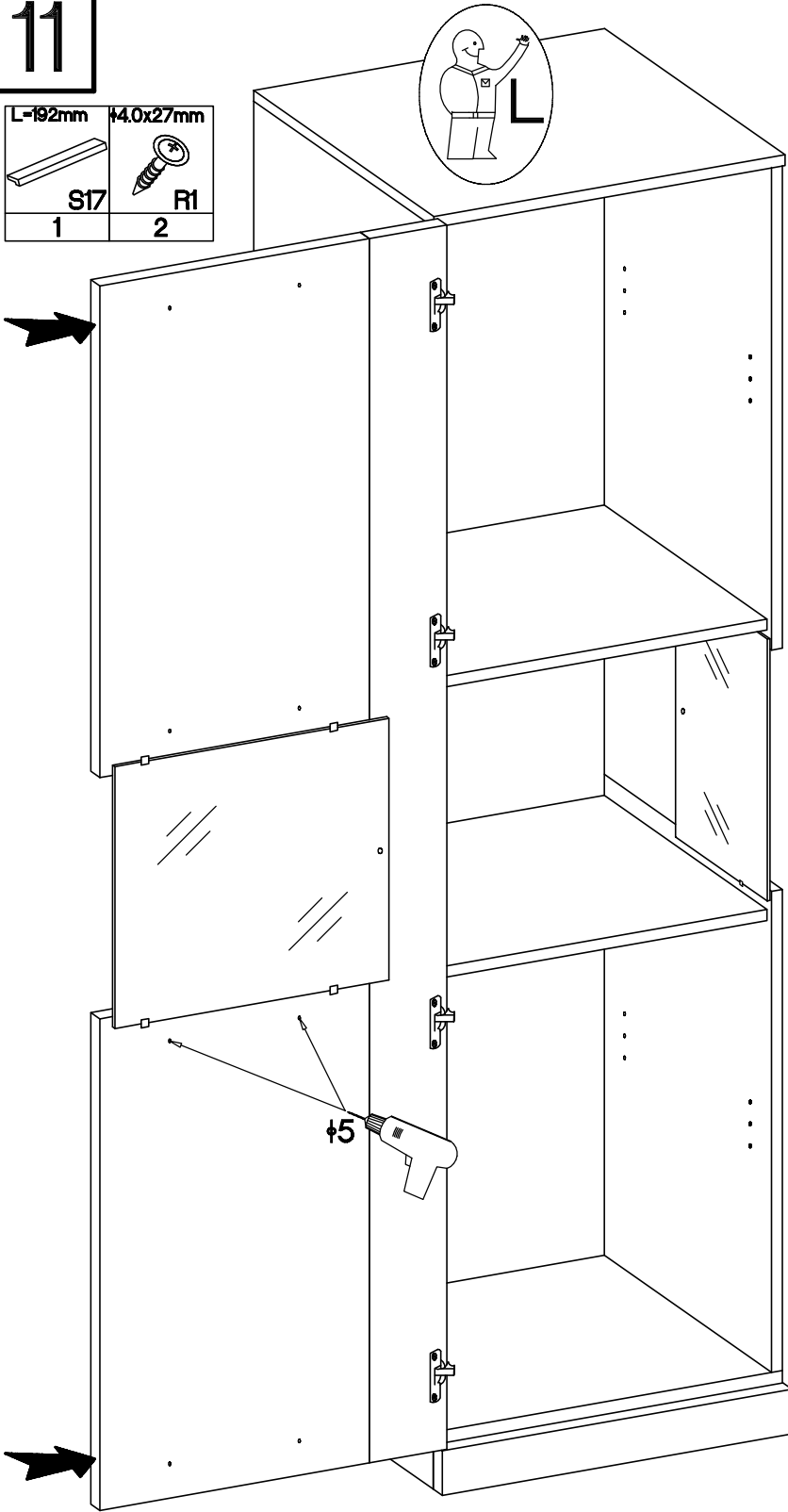

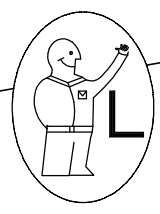

#4 E13	E	J3
1	16	8

