

Montageanweisung / Installation instructions / Instruction de montage / Istruzioni di montaggio  
montagehandleiding / Instrukcja montażu / Montaj talimatlar / Összeszerelési útmutató / Návod k montáži /  
Návod na montáž / Instrucțiune de montaj / Инструкция по монтажу / Montaj talimatina / Monteringsanvisningar  
Upute za montažu / Instrucciones de Montaje / Navodila za montažo

# PALMA

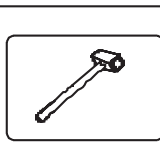

Total Kollis 3 Stuecke  
Total colli 3 pieces  
Numero total des colis:3  
Colli totali 3  
Totaal 3 colli's  
Razem sztuk 3  
Toplam parçalar 3  
Celkem balíčky 3  
Teljes csomag 3  
Celkom balíčky 3  
количество Всего 3  
Total colete 3  
Totalt antal kollin 3  
Ukupno koleta 3  
Bultos Totales 3  
Skupno število paketov 3

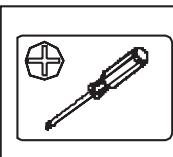
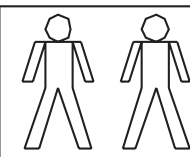
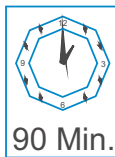
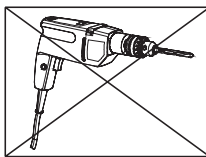
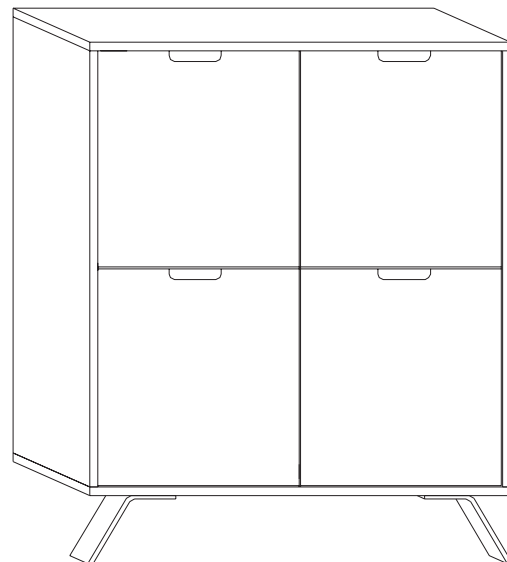
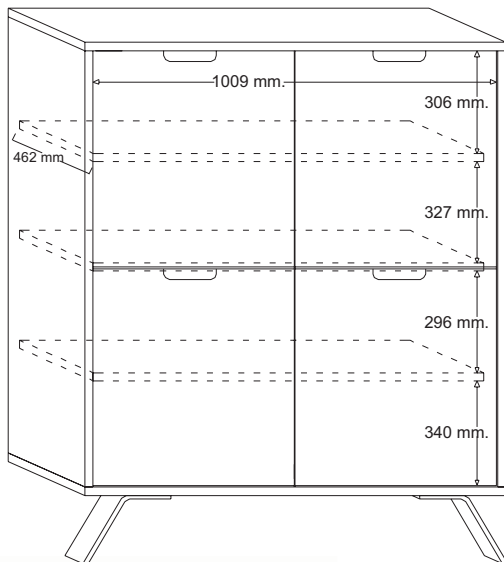

**D** Bitte lesen Sie diese Montageanleitung gut durch, da wir für Fehler, die durch falsche Montage entstehen, keine Haftung übernehmen!

**GB** Please read these installation instructions through carefully as we cannot accept any liability for faults occurring as a result of incorrect installation!

**CZ** Přečtěte si prosím pozorně tento návod k montáži, aby jste předešli chybám vzniklých špatnou montáží, za které neručíme!

**F** Veuillez lire attentivement cette notice de montage, car nous déclinons toute responsabilité en cas d'erreurs découlant d'un montage erroné !

**I** Prego leggere attentamente le istruzioni per il montaggio, poiché decliniamo qualsiasi responsabilità per difetti derivanti da un montaggio errato

**S** Läs monteringsanvisningarna noggrant. Vi avsäger oss allt ansvar för defekter som uppstår p.g.a. felaktig montering.

**HR** Pažljivo pročitajte upute za montažu, jer otklanjamo svaku odgovornost za pogreške nastale uslijed pogrešne montaže.

**SLO** Prosimo, da pozorno preberete navodila za montažo, saj zavračamo vsakršno odgovornost za napake, ki bi nastale zaradi napačne montaže.

**NL** Leest u alstublieft deze montagehandleiding goed door, voor fouten door verkeerde montage zijn wij niet verantwoordelijk.

**PL** Proszę uważnie zapoznać się z instrukcją montażu, ponieważ nie ponosimy odpowiedzialności za niewłaściwy montaż.

**HU** Kérjük, olvassa el figyelmesen ezt az összeszerelési útmutatót, mert a helytelen összeszerelésből a dőd hibákért nem vállalunk felelősséget!

**SK** Prosíme, dobre prečítajte si tento návod na montáž, pretože nepreberáme žiadne ručenie za chyby, ktoré vzniknú na základe chybnéj montáže!

**RO** Vă rugăm să citiți cu atenție aceste instrucțiuni de montaj deoarece nu preluăm garanția pentru defecte ce apar datorită unui montaj incorect!

**RUS** Пожалуйста, внимательно ознакомьтесь с данной инструкцией по монтажу, поскольку мы не несем ответственности за ошибки, причиной которых является неправильный монтаж.

**TU** İlkonce kullanma klavuzunu iyi okuyun, yalnız montaj yapmanız bunun sorumlusu biz değildir.

**E** Se ruego leer con atención las instrucciones de montaje debido a que declinamos cualquier responsabilidad por defectos derivados de un montaje erróneo





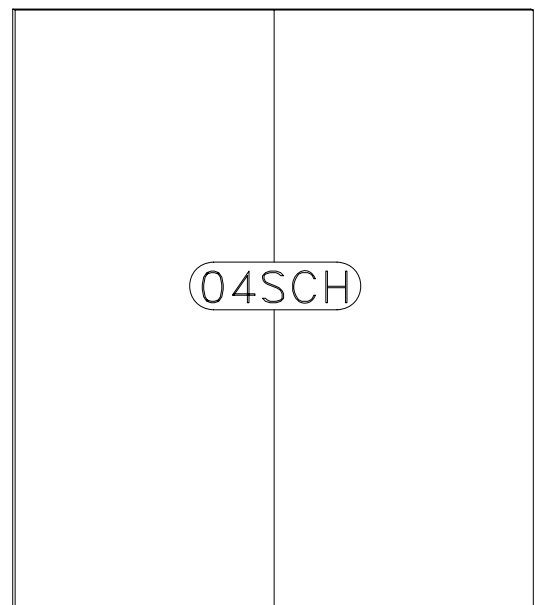
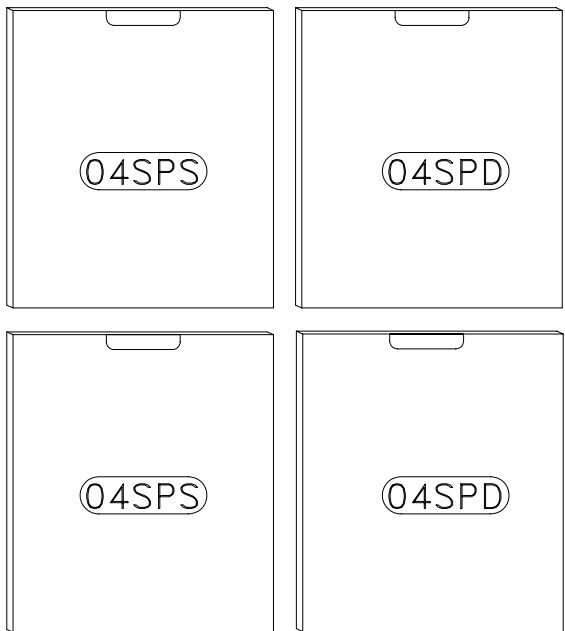
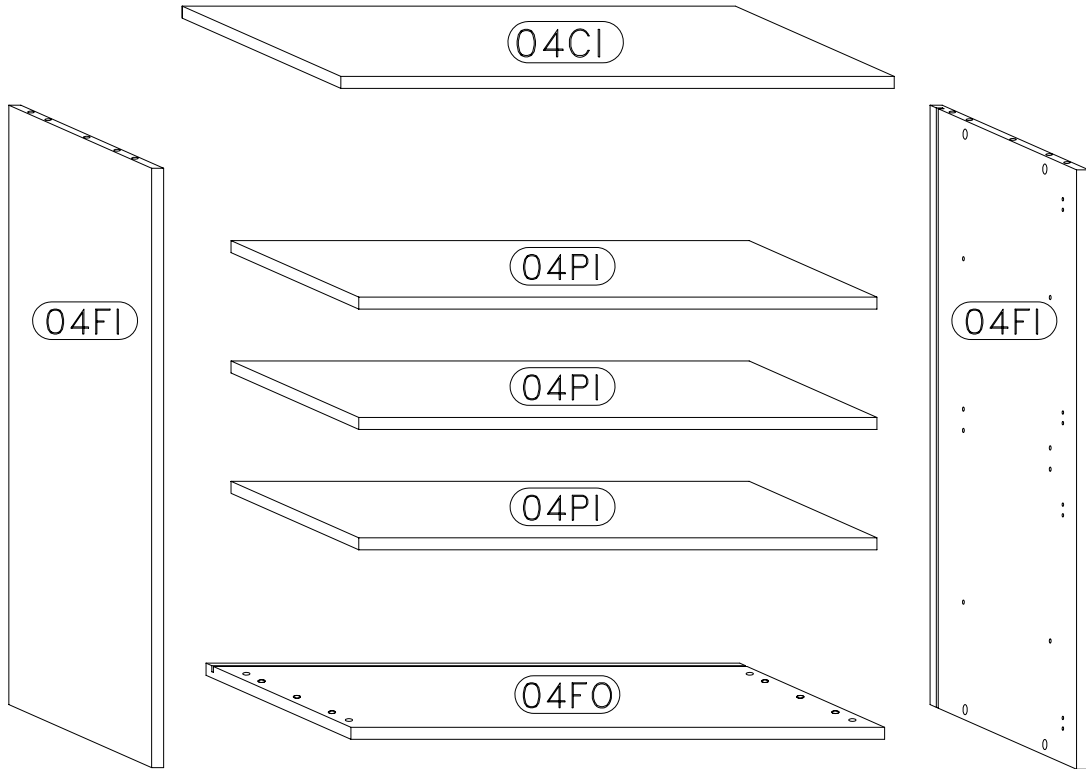
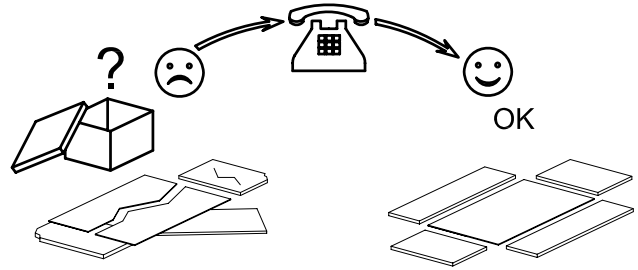
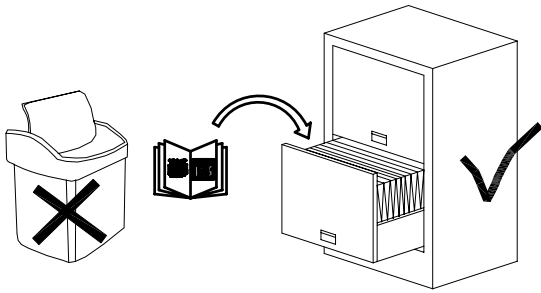

LC S.p.A  
Via del Piano s.n  
61030 Isola del Piano (PU)  
Italia

S E R V I C E K A R T E

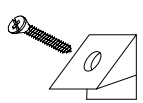
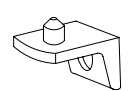
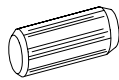

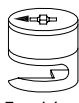

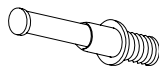
**ONDERDELEN LYST-SERVICEKARTE-FORMULAIRE DEMANDES SAV-SPAREPARTS LIST-SCHEDA DI SERVIZIO**

BESLAG-BESCHLAEGE - QUINCALLERIE - HARDWARE - FERRAMENTA

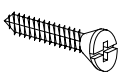
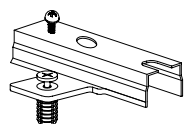
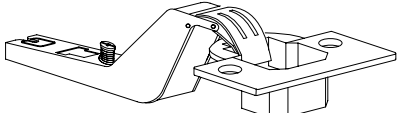
<b>A</b>		<b>205446-04CF</b>	<b>R2</b>	
	<b>x14</b>			<b>x12</b>
<b>B</b>		<b>M5</b>		<b>T4</b>
	<b>8x30 mm.</b>	<b>x12</b>	<b>6x9 mm.</b>	<b>x12</b>
				<b>6x25mm.</b>
				<b>x4</b>
<b>C8</b>		<b>P</b>		<b>T12</b>
	<b>ø15 x 14 mm</b>	<b>x8</b>		<b>x4</b>
				<b>6 ma X 12 mm.</b>
				<b>x4</b>
<b>D</b>		<b>P12</b>		<b>T13</b>
	<b>x8</b>	<b>ø20 mm.</b>	<b>x14</b>	<b>6x40 mm.</b>
				<b>x2</b>

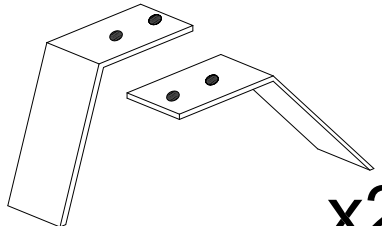
<b>L2</b>	<b>209025-07CC</b>	
		<b>x16</b>
	<b>4x16 mm.</b>	
<b>N0</b>		<b>x8</b>
	<b>H0</b>	
<b>O15</b>		<b>x8</b>

<b>205446-02PIE</b>

<b>x2</b>

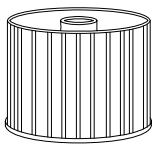
<b>P8</b>	
<b>205446-02TUB</b>	<b>x2</b>

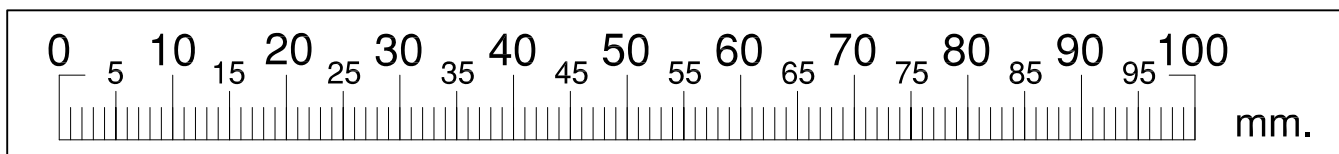
<b>P9</b>	
<b>529069-56TAP</b>	<b>x4</b>

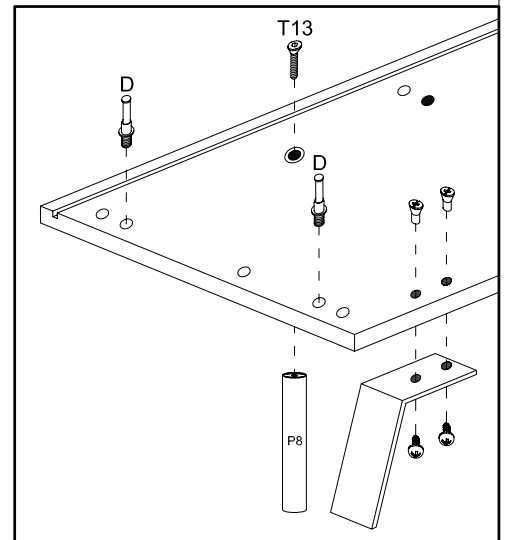
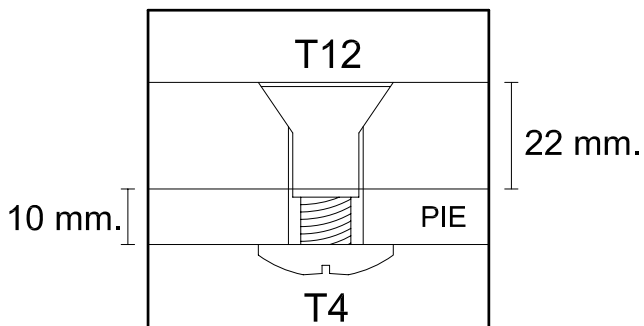
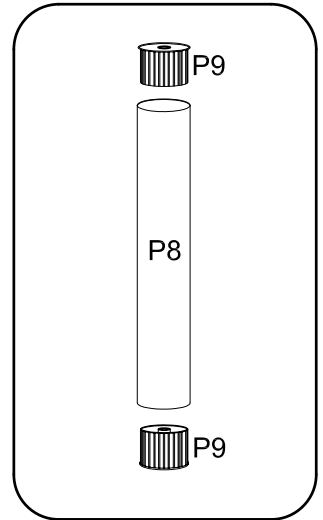
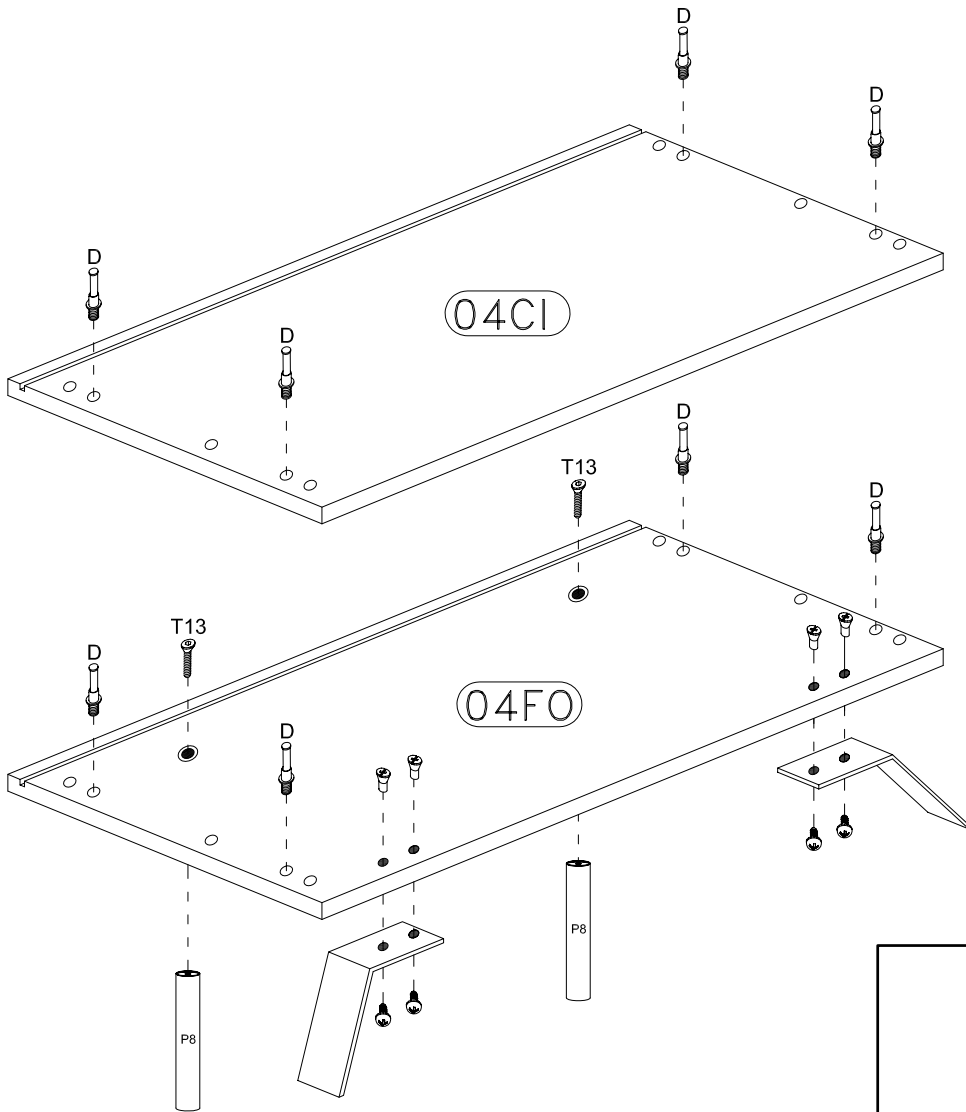
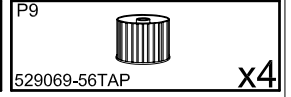
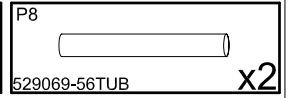
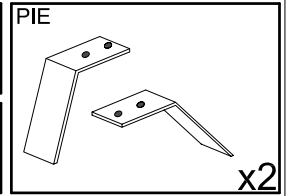
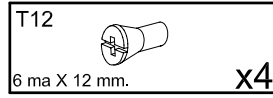
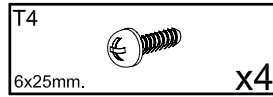
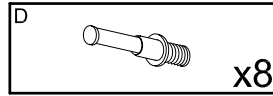
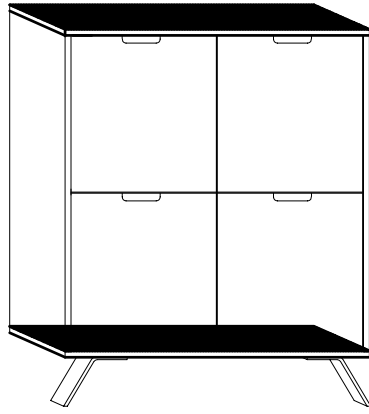
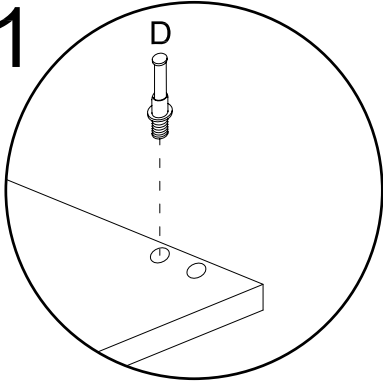

1



2

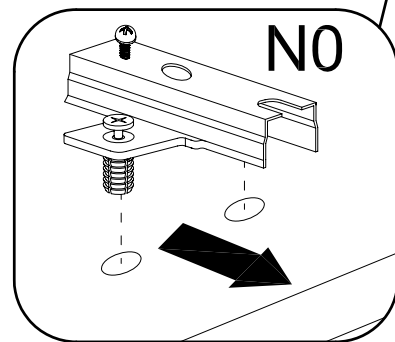
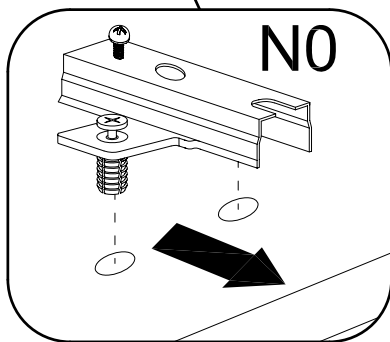
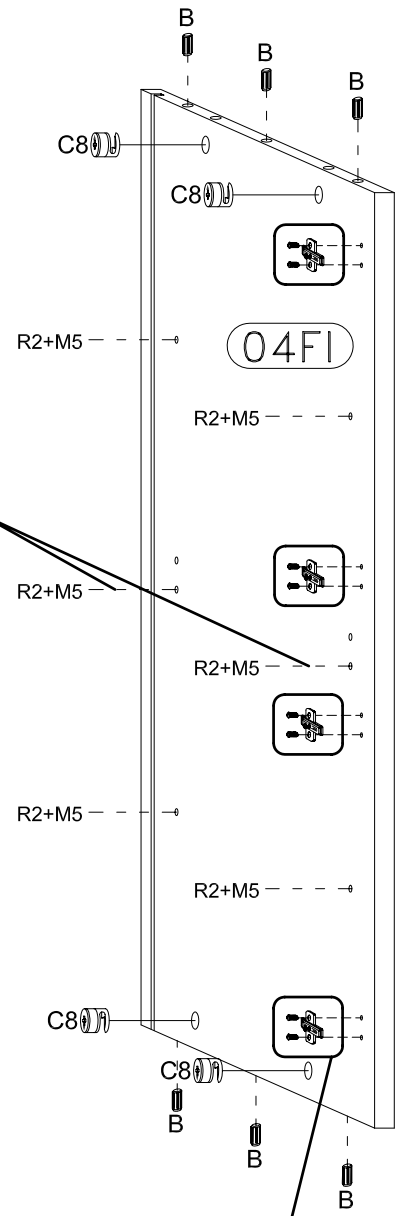
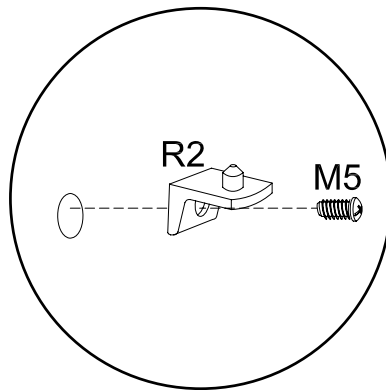
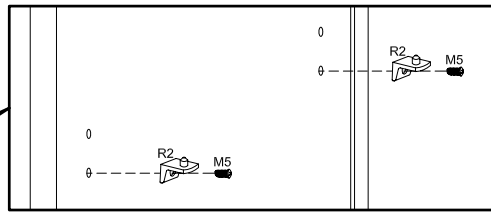
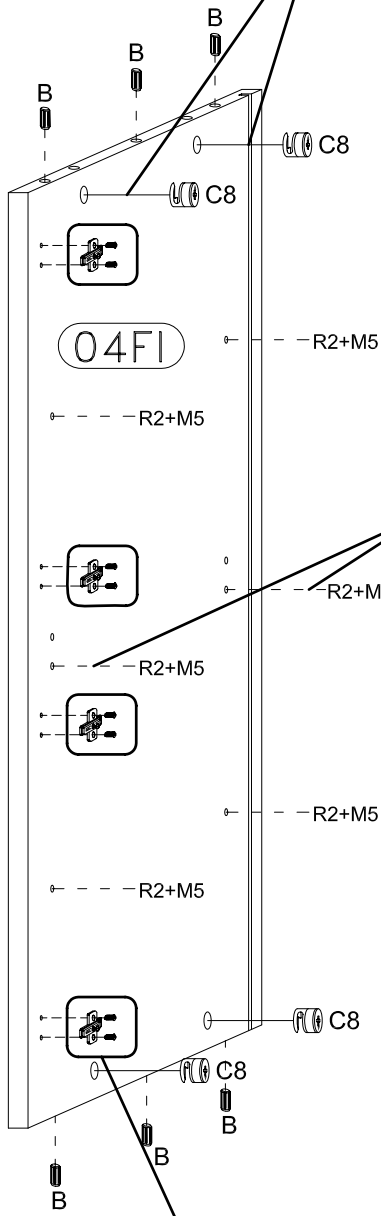
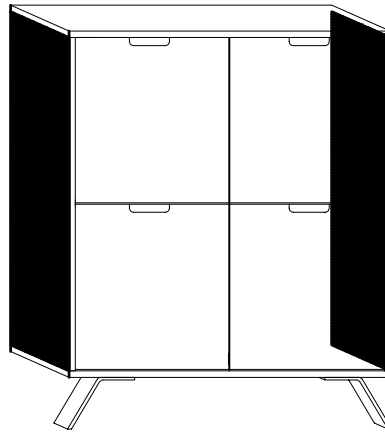
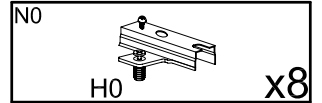
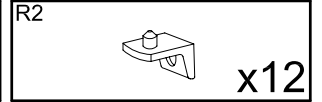
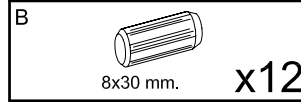
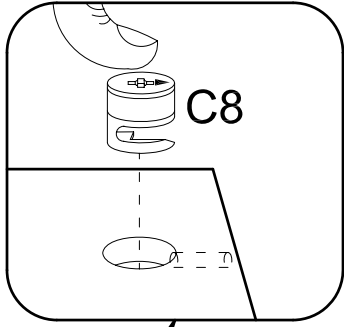

3

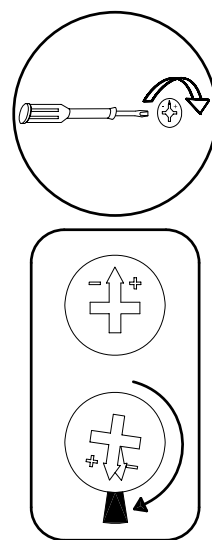
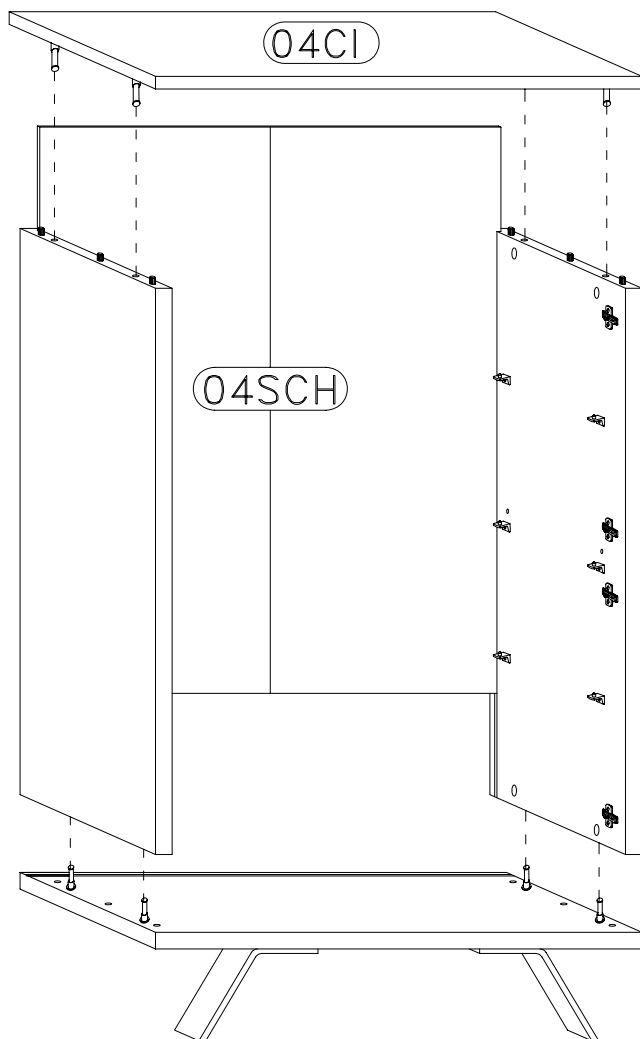

4

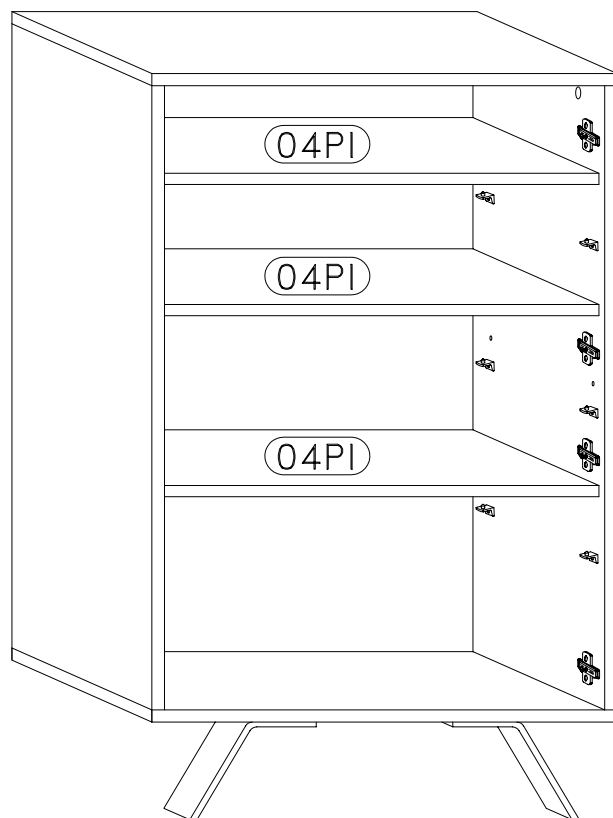

5

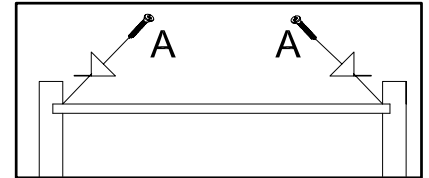
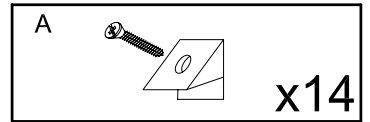
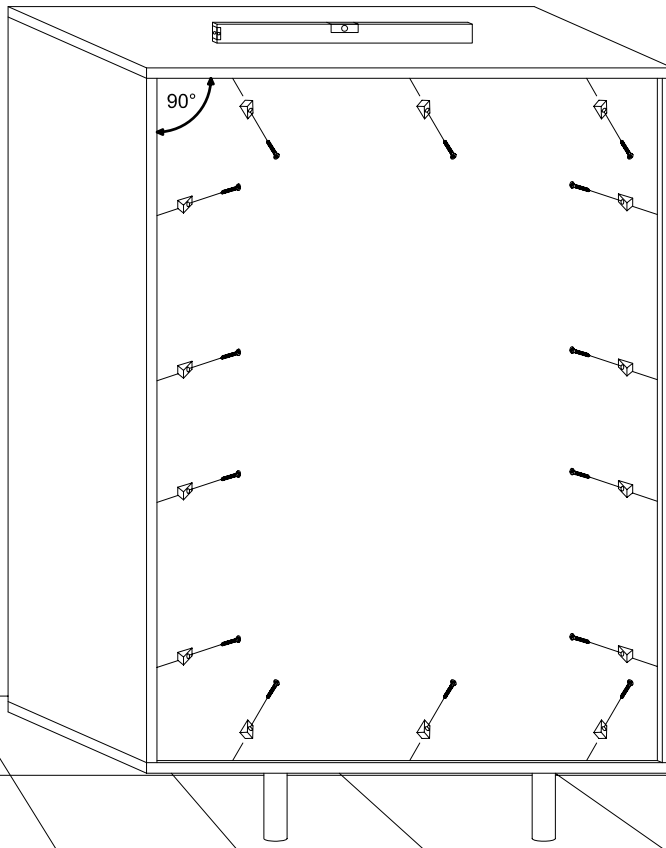

6

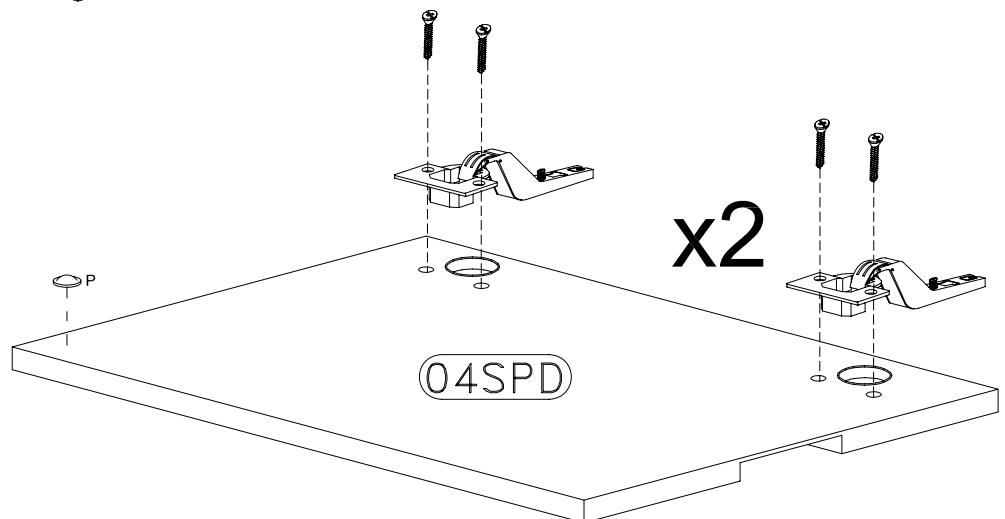
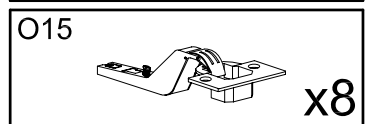
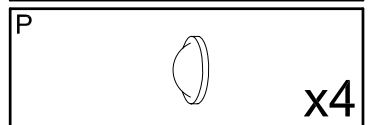
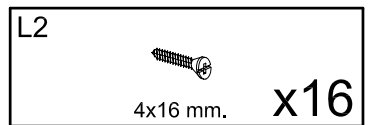
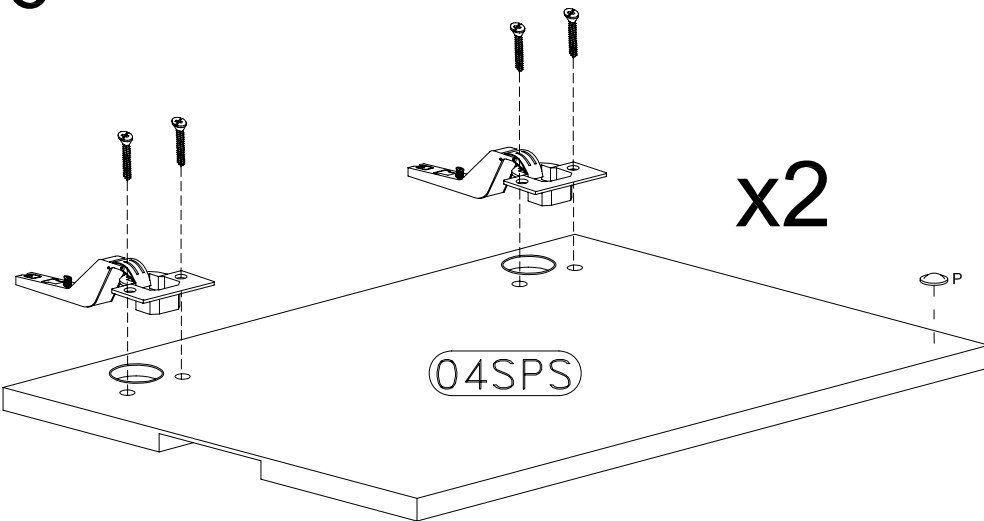

7

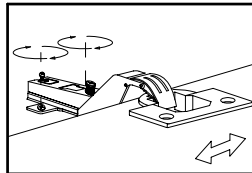
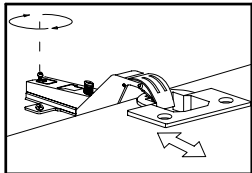
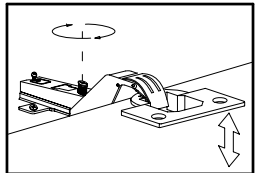
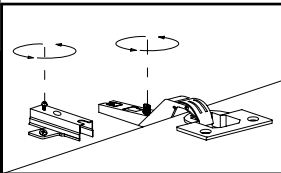
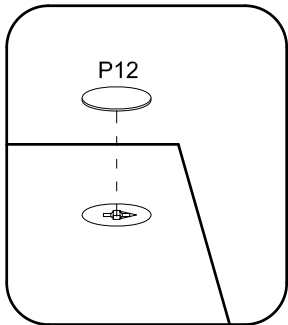
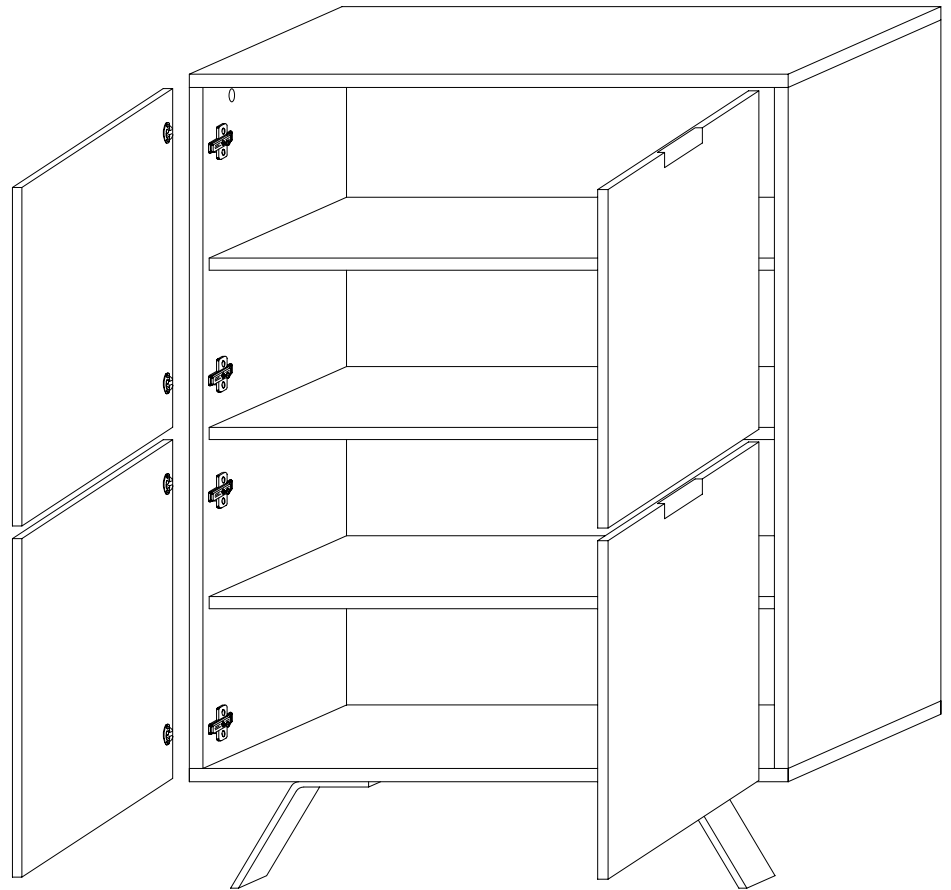

P12  
Ø 20 mm.  x14

